



**SUNRISE Fluid Power Inc.**

No. 7, Road 12, Industrial Zone, Taichung City 407, Taiwan

Tel: 886-4-2359-1190

sales@sunriseiw.com.tw

Fax: 886-4-2359-3409

www.sunriseiw.com

---

# **SUNRISE HYDRAULIC IRONWORKER**

**SINGLE CYLINDER MODELS  
IW-45M, IW-50A, IW-60H**

**OPERATION &  
MAINTENANCE MANUAL**

**Original Instructions**

**632EG013**

**12-2012**



## TABLE OF CONTENTS

Introduction .....	1
Safety Precautions .....	2
Transport .....	6
Installation .....	7
Lubrication .....	9
Standard Equipment .....	10
Control Switches .....	11
Low pressure tool alignment with JOG mode.....	14
Foot Switch .....	15
Optional Electric BackGauge .....	16
Stroke Adjustment .....	17
Adust the Main Central Shear Slide .....	19
Adjust the Punch Ram (IW-50A Only) .....	19
Punching Station .....	20
Standard Equipment .....	20
Alignment of Punch and Die .....	20
Punch and Die Clearance .....	21
Adjusting Stripper .....	21
Actual Punching Force .....	22
Precaution .....	22
Punch and Die Lubricant .....	22
Punch Operation .....	23
Punching Station Assembly .....	26
Flat Bar Shearing Station .....	27
Blades .....	27
Cutting Clearance .....	27
Precaution .....	28
Flat bar Shear Operation .....	29
Angle Flange Shear Operation .....	29



Angle Shearing Station .....	30
Blades .....	30
Cutting Clearance .....	30
90 Degree Shear Operation .....	31
45 Degree Internal Miter Shear Operation (on IW-45M and IW-50A) .....	32
45 Degree Internal/External Miter Shear Operation (on IW-60H only) .....	32
Square/Round Bar Shear Station .....	34
Cutting Clearance .....	34
Precaution .....	34
Bar Shear Operation .....	34
Notching Station (On IW-50A and IW-60H) .....	36
Blades .....	36
Bolster Adjustment .....	36
Notching Operation .....	37
Maintenance .....	38
Trouble Shooting .....	40
Hydraulic Circuit Diagram .....	42
Hydraulic Parts List .....	43
Electrical Circuit Diagram IW-45M .....	44
Electrical Parts List IW-45M.....	45
Electrical Circuit Diagram IW-50A, IW-60H.....	46
Electrical Parts List IW-50A, IW-60H.....	47
Electrical Circuit Diagram IW-50A, IW-60H with sensor.....	48
Electrical Parts List IW-50A, IW-60H with sensor .....	49



**SUNRISE Fluid Power Inc.**

No. 7, Road 12, Industrial Zone, Taichung City 407, Taiwan

Tel: 886-4-2359-1190

sales@sunriseiw.com.tw

Fax: 886-4-2359-3409

www.sunriseiw.com

---

## **INTRODUCTION**

The Sunrise Ironworker is a hydraulically powered punching and metal shearing machine. The machine is equipped with Punching, Flat Bar Shearing, Angle Shearing, Round Bar / Square Bar Shearing, and Notching stations (on IW-45M, the notcher is an optional tooling installed at the punching station). This multi-function aspect allows the Sunrise Ironworker to meet the diversified needs of the metal forming industry. There are many optional accessories that will further increase the versatility of the machine, contact our dealer for details.

Each machine has been individually tested in the factory and under-gone an extensive pre-delivery check to ensure that the machines meet the highest quality standard. The ironworker has been designed to be a reliable and dependable machine with excellent performance. We know the working quality of the machine will confirm that you have made a good choice by selecting Sunrise products for your facility.

In order to have a better understanding of the operating procedures, to obtain maximum benefits from the machine, and to minimize the maintenance cost of the equipment, please have the operators and engineers read this Manual thoroughly and carefully before operating the machine.



## **SAFETY PRECAUTIONS**

### **IMPORTANT:**

**It is the duty of both employer and employees to acquaint themselves with the safe working practices contained in this manual and ensure that all operators adopt these practices.**

While every effort has been made to furnish sufficient safe guards, this equipment, if not operated and maintained properly, has the potential to cause serious injury or death. A thorough knowledge of the machine and operating with carefulness is the best protection against accidents.

All operations are controlled by either the foot switch or by the optional electric backgauge. The operator should be familiar with the control and function of the switch/backgauge before perform the operation.

Many warning labels are fixed on the machine. **NEVER REMOVE THESE LABELS.** Be sure to follow these warnings to avoid injury. Please also pay attention to the following general rules:

1. Do not operate the machine unless all safety guards and hold-downs are in place. Use of optional attachments/tooling should also have proper hold-downs and guards installed. If any guards are damaged or worn out, replace immediately with new guards.
2. On the single cylinder models, only one operator is allowed to operate the machine. Before each operation, make sure no other person is near the machine.
3. **Operator must wear Protective Glasses during operation to protect the eyes.**
4. **Keep hands clear of all moving parts at all times. Fingers must not go under or inside the danger zone established by the safety guards, stripper, and/or holddowns.**
5. On IW-50A and IW-60H which has a notcher, the nature of the station requires opening the notcher safety cover during notching operation for processing different shape and sizes of materials. This creates a potential

risk to the operator. When using the notching station, open the notcher safety cover only as much as the job required. If notching flat plate, do not open the cover all the way up. The notcher safety cover is interlocked by the SHEAR/NOTCH selection switch. **Notcher safety cover must be closed when not using the notching station.** During notching operation, keep fingers away from moving parts. Do not notch material that operator cannot hold firmly during notching. Exercise caution and be alert to potential risks.

6. Any maintenance/repair of electrical/hydraulic circuit; change/adjust of blade/tooling; and alignment of punch-die should be done only by qualified engineers or personnel.
7. Always turn off power and disconnect electric supply before doing any tool change or maintenance work.
8. After tool changes, always check punch & die alignment and blade clearances before operation.
9. **Always adjust the stripper to be only about 2mm above the working material. When punching thinner material, lower the stripper.**
10. Do not punch, shear, or notch parts that are too small to fit under the safety hold downs.
11. If any problem or abnormal condition arises during operation, stop the machine immediately and report to a supervisor. Do not turn on the machine again until the problem is rectified by qualified personnel.
12. The machine should never be left under power when not in operation or unattended. Always isolate the machine after turned the power off.
13. After completion of operation, all slugs and waste materials must be cleaned away from the machine.
14. Regularly check all stations and tooling for defects and wear to ensure safety and maintain good condition.
15. Heavy materials should be supported.



16. Use handling equipment when lifting heavy tooling and materials.
17. Do not punch partial holes as this creates a side load force on the punch and can result in tool breakage. Special tooling may be available for this purpose.
18. **Do not punch material thicker than the diameter of the punch.** Doing so can overload and break the punch and create a hazard. The punch on IW-45M and IW-60H comes down in arc motion; add more clearance between punch and die, especially for thicker material.
19. Never exceed the rated capacity of the machine. Refer to the specification chart for details for each model.

**The manufacturer shall not be held for any liability for damages/body injuries or other consequences to machine, material, and persons caused by the non-compliance of the above safety precaution procedures, in particular for the following situations:**

- 1. Removing or disabling any guards or hold-downs is a violation and will result in the termination of your warranty.**
- 2. Place of any body part under or inside the danger zone established by the safety guards, stripper, and/or holddowns.**
- 3. Did not wear protective glasses for the eyes.**
- 4. Did not close the stripper during operation.**
- 5. Did not close the notcher safety cover when using other workstations.**
- 6. Did not properly adjustment the clearance resulting the punch/die/blades hitting each other.**
- 7. Did not interrupt the main electric power supply before any maintenance work.**
- 8. Damage of electric parts or risk of fire due to incorrect electric power supply.**
- 9. Damage of pump or other hydraulic parts due to incorrect setting of the limit switches.**

## **DANGER**

- **KEEP HANDS CLEAR OF ALL MOVING PARTS.**
- **ALL GUARDS AND HOLD-DOWNS MUST BE IN POSITION BEFORE OPERATING THE MACHINE.**
- **ALWAYS POSITION MATERIAL UNDER A CORRECTLY SET HOLD-DOWN. NEVER ALLOW THE MATERIAL TO FEED BEYOND THE HOLD-DOWN.**

## **CAUTION**

- **THOROUGHLY READ THE OPERATION MANUAL BEFORE OPERATION.**
- **TURN OFF POWER AND ISOLATE THE MACHINE WHEN CHANGING TOOLING OR DOING MAINTENANCE.**
- **ALL MAINTENANCE/REPAIR WORK MUST BE DONE BY QUALIFIED PERSONNEL.**
- **IF ANY PROBLEM OR ABNORMAL CONDITION OCCURS, STOP THE MACHINE IMMEDIATELY. DO NOT OPERATE THE MACHINE AGAIN UNTIL THE PROBLEM IS FIXED.**

**Opertators's working positions:**

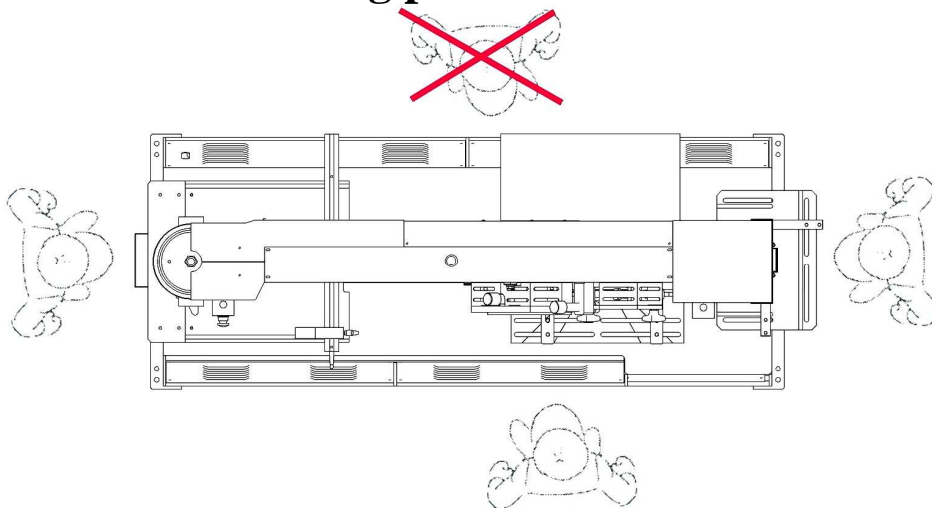

## **TRANSPORT**

When transporting the machine by a crane, hook the crane to the eye bolt on top of the machine. **Do not use slings under the machine.** Pay special care if lifting / transporting the machine with forklifts. The forks should extend fully to cover the width of the machine. **Do not put the forks from either end.**

**NOTE:** As the top of the machine is heavy, the high center of gravity can cause the machine to tip over if machine is not in good balance.

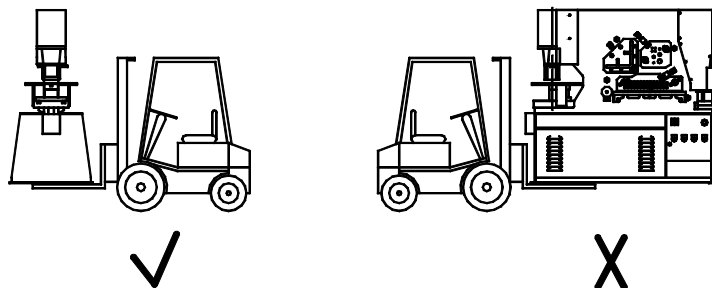
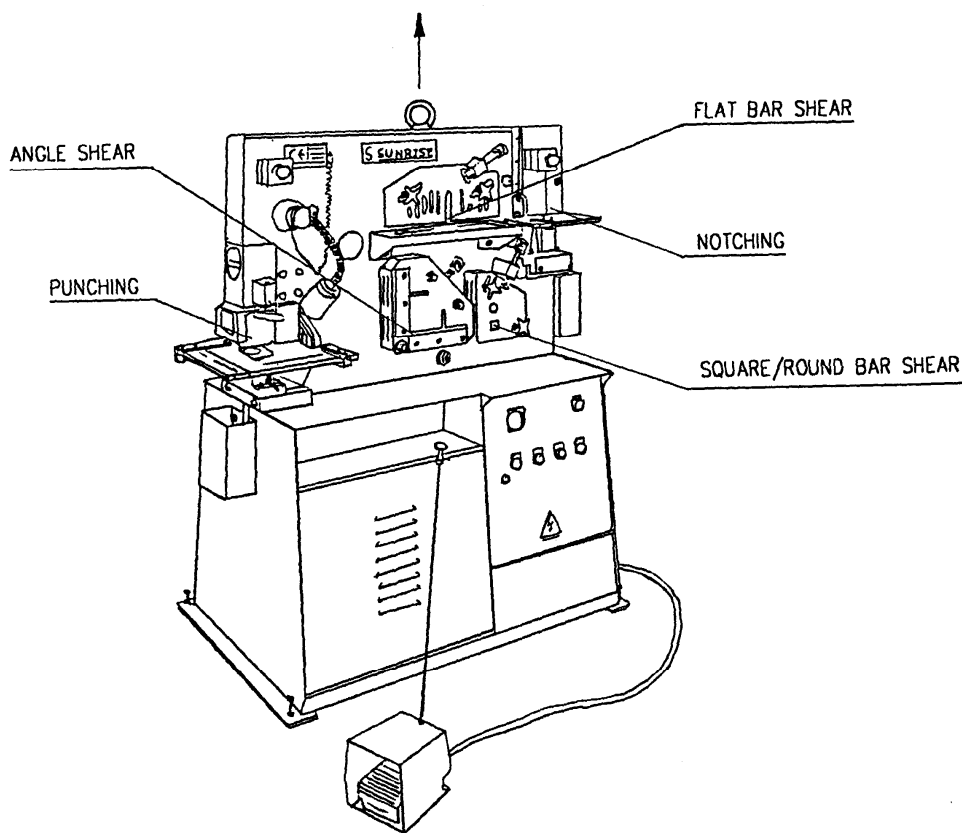

## **INSTALLATION**

The machine only requires the normal industrial concrete foundation. If the ground is uneven and the machine vibrates during operation, use foundation bolts to tighten the machine firmly to the ground or alternatively mount the machine on anti-vibration pads.

### **IMPORTANT:**

- Maintain a spacious working area around the machine for safety.
- Have the work area well illuminated with proper lighting.
- Clean the scraps and waste materials regularly, and make sure the work area is free of obstructing objects.
- Keep the ground free of oil and make sure it is not slippery.
- If long lengths of material are to be fed into the machine, make sure that they will not extend into any gangways.

*Crowded, poorly illuminated or slippery area are often causes for accidents.*

Remove all anti-corrosion grease after installing the machine. Check that the oil reservoir, located in the machine base, has been properly filled. When refilling oil, use recommended oil and fill the reservoir to the upper level of the oil level gauge.

### **Connecting Power Supply**

Electrical wiring must be done by a qualified electrician. Before connecting the electrical supply, make sure the voltage and current is compatible to the electrical components in the machine. Check the data shown in the electrical control box.

**IMPORTANT: Turn off Supply Electricity at your facility's circuit breaker before making electrical connections to the machine.**

To connect the power cord:

- 1) Open the electric box.
- 2) Remove the small panel under the electric box.
- 3) Insert the power cord through the entrance hole on the base of machine, and then through the base of electric box.
- 4) Connect the three phase wires to the power terminal strip in the electric box.
- 5) Also make sure to ground the machine properly.
- 6) Check that the power cord surface is not damaged, scratched or cut during installation.
- 7) Reinstall the panel and close the electric box.

To check the correct rotation of the motor.

- Remove the back cover.
- Briefly start and stop the motor and check that the motor rotates in the same direction as the arrow indicated on motor. **Improper rotation can severely damage the pump.**
- To change the motor rotation, first make sure the power is disconnected, then reverse any two of the three phases of the electrical power supply.

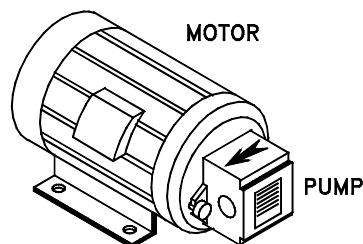

## LUBRICATION

Lubricate the machine with recommended grease every 8 working hours. Use the grease gun provided to supply grease to all lubrication points, which are located on both sides of the machine as shown in the figure.

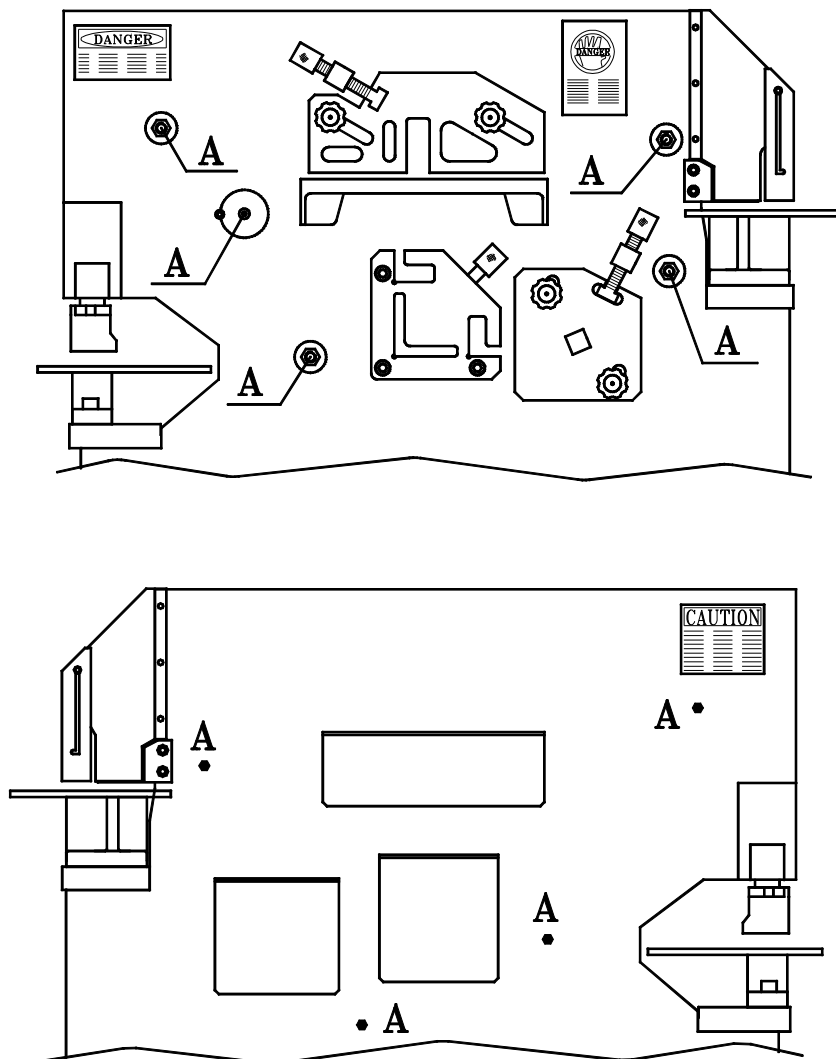

**A: Lubrication Points**



## RECOMMENDED GREASE

Lubricant Grease (or equivalent):

Esso	Beacon 2
Shell	Alvania Grease R-2
Kraff	KL2

## STANDARD EQUIPMENT SUPPLIED WITH MACHINE

(including items pre-installed on the machine)

Flat Bar Shear Blades	1 set
Angle Shear Blades	1 set
Round & Square Bar Shear Blades	1 set
Rectangular Notch Blades	1 set*
Punch and Die (20mm)	1 set
Punch Support Table	1 pc
Notch Support Table	1 pc*
Punch Retaining Nut / Sleeve	1 set
Die Holder	1 pc
Punch Stripper Unit	1 pc
Spotting Light	1 pc*
1 Meter backgague	1 pc
Work station Safety Guards	1 set
Lifting Eye Bolt	1 pc

\* : Not supplied on IW-45M

TOOL BOX	1 pc
Grease Gun	1 pc
Adjustable Spanner (250mm)	1 pc
Screw Drivers (+)	1 pc
Screw Driver (-)	1 pc
Hex Key Wrench Set	1 set
Hex Wrench (12mm)	1 pc
Hex Wrench (14mm)	1 pc
SPA Spanner	1 pc



## **CONTROL SWITCHES**

**EMERGENCY STOPS** – Use the EMERGENCY STOP buttons to stop the machine in an emergency. The emergency buttons must be released before the PUMP ON button will function. To release the emergency stop buttons, turn knob slightly to the right.

**ISOLATOR Switch** - This switch controls the main electric source. It also functions as a lock for the electric box. At the ON position the switch locks the electric box and enables you to start the machine. At the OFF position, the power is cut off and the electric box can be opened.

**PUMP ON** - Push this button to turn on the machine. All EMERGENCY STOP buttons must be released before the PUMP ON button will function. The green POWER LIGHT stays on when the machine is turned on.

**PUMP OFF** - Push this button to turn off the machine.

**PUNCH/SHEAR/NOTCH Switch** (for IW-50A and IW-60H) - Use this switch to select between punching, shearing or notching operations. In PUNCH and SHEAR mode, the slide travels in full distance set by the upper and lower stroke limit switches. In the NOTCH mode, the slide travels at a shorter distance set by middle and lower stroke limit switches.

**Note:** The PUNCH/SHEAR/NOTCH switch is electrically interlocked with the Notch Safety Guard. When in PUNCH and SHEAR mode, the machine is IMMOBILIZED if the Notch Safety Guard is lifted. Please also refer to the section on stroke adjustment.

**Note for IW-60H only:** Because of the design of the location of the square/round bar shear station, the operation of the bar shear station on IW-60H is in the same selection as the punching operation. In other words, when shearing square/round bars, turn to PUNCH mode instead of Shear mode. Use SHEAR mode for flat shear and angle shear.

**PUNCH/SHEAR Switch** (for IW-45M) - Use this switch to select punch or shearing operations.



**NORMAL/JOG Switch** - This switch allows selection between the normal (automatic return) mode and the jog (low pressure, slow speed, non- return) mode. Use the normal mode to operate the machine. Use the jog mode to align punch/die, to set blade clearance, and to set the strokes. In NORMAL mode, the ram/slide move in both up and down directions. In JOG mode, the hydraulic system is in low pressure setting and the ram/slide move only in downward direction at slower speed. Also refer to the section on Low Pressure Tool Alignment in JOG mode.

**AUTO/MANUAL Switch** (for machines equipped with the optional electric backgauge only) - Turn to AUTO to use the backgauge, and turn to MANUAL to use the foot switch. Also refer to the section on electric backgauge.

**IMPORTANT WARNING:**

On IW-45M, IW-50A, and IW-60H models, in PUNCH mode the cylinder/slide moves in opposite direction as to the SHEAR/NOTCH mode. Therefore, when switching from Shear or Notch mode to PUNCH mode, the cylinder starts moving and the Shear/Notch Blades will come down. Similarly when switching from Punch mode to SHEAR or NOTCH mode, the cylinder starts moving and the Punch will come down. **This has the potential of body injury. Before turning the PUNCH/SHEAR/NOTCH switch, be very careful and make sure that the punching stripper and notcher cover are closed, that no materials are in any of the workstations, and that all fingers and body parts are away from all moving parts. ONLY for the supervisor and his trained authorized operator of the machine who understands the potential risk of the machine and is authorized to use the notching station.**

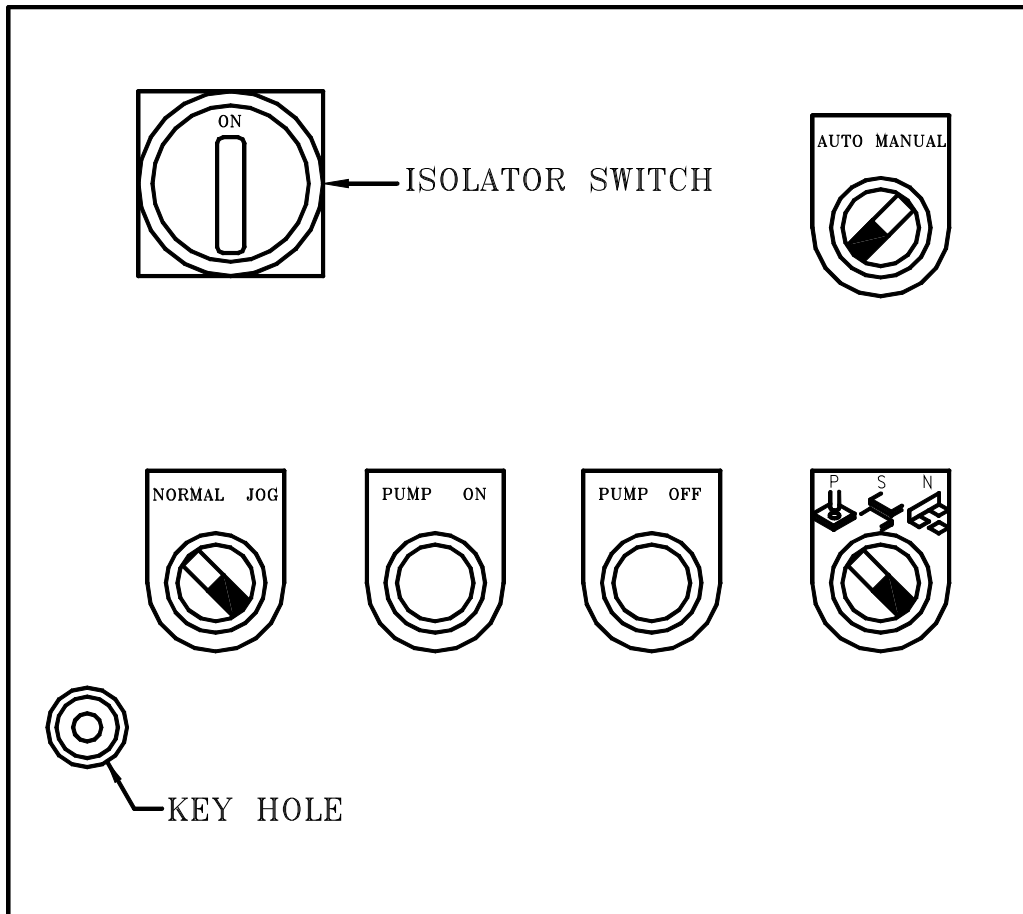



**SUNRISE Fluid Power Inc.**

No. 7, Road 12, Industrial Zone, Taichung City 407, Taiwan

Tel: 886-4-2359-1190

sales@sunriseiw.com.tw

Fax: 886-4-2359-3409

www.sunriseiw.com

---

## **Low pressure tool alignment with JOG mode**

Sunrise Fluid Power Inc. is the market leader in providing low pressure tool alignment setting on its products. When the NORMAL/JOG switch is turned to JOG mode, the machine provides a low pressure and low speed setting for safer tool alignment operation. This will reduce tool damages due to misalignment of tools and increase the operator safety. If a material is placed under the punch in JOG mode, the punch will only make a dent on the material without punching through. In addition, the punch cylinder will only move downward when the foot pedal is pressed, and will not retract backup when the foot pedal is released. Turn the NORMAL/JOG switch to NORMAL to move the cylinder upward.

The JOG mode works for all working stations. The safety cover of other stations **MUST** be closed for the machine to move.

**WARNING: for ease of tool alignment, the stripper cover is allowed to open in JOG mode. Even with the low pressure setting, be sure to keep all body parts away from moving parts, wear appropriate eye protection goggles and gloves for eye and hand protection. The JOG mode is a keyed switch, and only properly trained and authorized personnel should have access to the key and use the machine with JOG mode.**

## FOOT SWITCH

The machine uses a foot switch for easy and fast operation control. The foot switch enables the operator to use the machine while holding the work piece with both hands. NEVER has one operator hold the material and another operator press the foot switch.

The foot switch has three positions: UP, HALFWAY and DOWN.

UP position is when you release the foot switch completely.

HALFWAY position is when you press or release the foot switch halfway.

DOWN position is when you press the foot switch all the way down. When not pressed, an internal spring pushes the switch to the UP position. The foot switch functions differently in the NORMAL and the JOG modes.

**In NORMAL mode**, press the foot switch to DOWN position for the downward motion of the slide. Release the foot switch to HALFWAY position will cause the slide to stop. This is very useful in position the work piece without using the gauge stoppers. Press the foot switch again to Down position and the slide will continue moving downward until reaching the lowest position set by the limit switches. Releasing the foot switch completely (UP position) will cause the slide to return to its up position.

**In JOG mode**, press the foot switch to the DOWN position for the downward motion of the slide. The slide stops moving when the foot switch is released to either HALFWAY position or UP position. The slide does not move back up even when foot switch is completely released. This allows the operator to make necessary adjustment / alignment. In other words, the slide moves only in one direction in JOG mode. To move the slide back to the up position, switch the Normal/Jog switch to NORMAL.

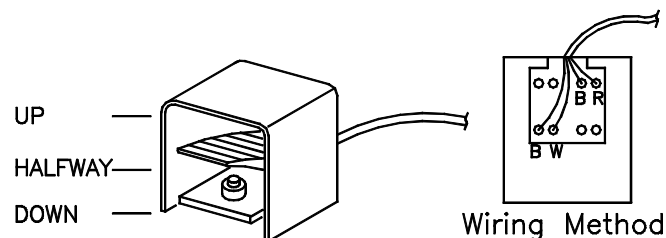

## ELECTRIC BACKGAUGE

Optional electric touch-and-cut back gauge is available to control the movement of the machine (instead of using the foot pedal). To use the electric back gauge, turn the Auto/Manual switch to AUTO. To use the foot switch, turn the switch to MANUAL.

### To use the electric backgauge:

- 1) Install the two pipes of the backgauge.
- 2) Connect the sensor wire to the socket on the back of the machine with the key way correctly aligned.
- 3) Turn the switch to AUTO.
- 4) Adjust the back gauge to the desired length.
- 5) Position the sensor on the back gauge so that the working piece will touch the sensor during operation.
- 6) To operate, simply push in the work piece. When the sensor is touched by the work piece, the blade will start moving down after a short delay. The delayed time can be adjusted by a timer inside the electrical box. After the shear, the cut piece falls out and the blade automatically returns to the up position for the next shear.
- 7) If the length of the sheared piece is not the same as the reading on the backgauge, there is an adjustment nut on the backgauge to set the zero-position of the backgauge reading.

**NOTE:** Once the sensor is touched and the shearing operation has started, *the machine will complete the whole shearing cycle*. The machine cannot be stopped halfway unless the emergency stop button is pushed. Although the electric backgauge increases the working efficiency, special care is required when using this function. Carelessness often causes accidents.

## **STROKE ADJUSTMENT**

Certain working operations do not require a full working stroke. For large quantities of the same operation, merely execute the required working stroke distance to save operating time. The position and length of the cylinder strokes are controlled by adjusting the limit switches and actuators on a drive bar installed on the back of machine.

### **For IW-45M:**

There are two limit switches, one for the upper limit and one for the lower limit. The role of the limit switches changes from Shear mode to Punch mode. In other words, the upper limit in Shear mode becomes the lower limit when switched to Punch mode, and vice versa.

### **For IW-50A and IW-60H:**

There are three limit switches, one for the upper limit, one for the lower limit, and one for the notch upper limit (short stroke). At SHEAR and PUNCH mode, the slide moves in full length between the right limit switch and the left limit switch. The role of the limit switches changes from Shear mode to Punch mode. In other words, the upper limit in Shear mode becomes the lower limit when switched to Punch mode, and vice versa. In NOTCH mode, the center limit switch functions as the upper limit (short stroke), and the slide moves between the center and left limit switches.

Note: the center actuator for the center limit switch must be adjusted to stay at the left side of the limit switch. This enables the stroke movement between the center and left limit switch in the Notch mode. Fail to do so will result in the machine not function properly.

**IMPORTANT:** The limit switch must be actuated before the Cylinder reaches the full extend or full extract position. In other words, the pump should be unloaded in upper or lower limit of the slide travel. *Fail to do so can overload the motor and damage the pump.* If the pump is not in unloading position at either upper or lower limit, a loud noise can be heard from the pump. Immediately turn the machine off and adjust the limit switch actuators to set the proper stroke movement.

## IW-45M

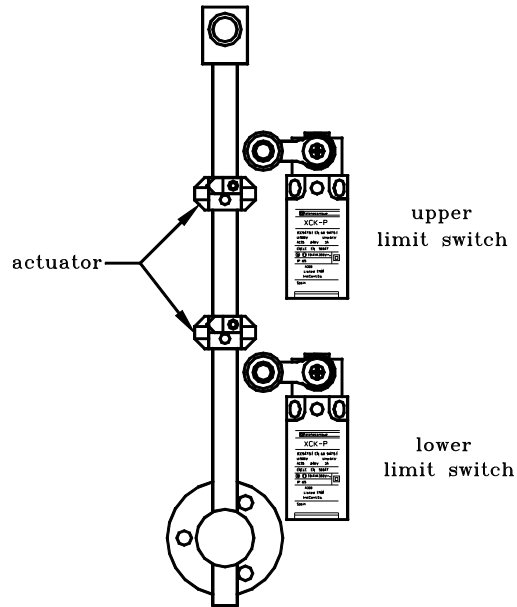

## IW-50A, IW-60H

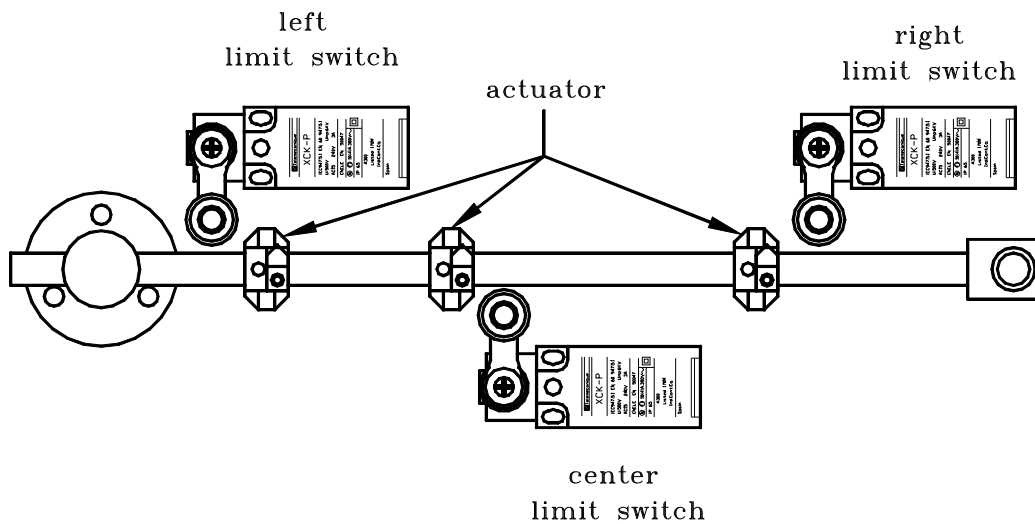

## **ADJUST THE MAIN CENTRAL SLIDE**

- 1.) The main central slide (holding the moving shear/notch blades) should be pushed against the back of the machine body. Adjustment of the central slide is carried out by setting the "Pressure Pads". These pads are located on the front body of the machine. They can easily be identified as each has a grease nipple (same location as the grease points).
- 2.) Turn on the power. Then tighten the Pressure Pad Screws while moving the center slide up and down. The pressure pad screws should be adjusted in the diagonally cross order. Then turn reverse the screws to loosen them slightly, so the pads are touching but not pressing with force against the center slide. Repeat the procedure for each of the pressure pads to make sure each screw is adjusted evenly. Avoid too much pressure on any single pressure pad.
- 3.) When finished with adjustment, lock in position by tighten the locking nuts for each screw. Be sure to use two tool for the screw and nut, so screw does not turn and over tighten while tightening the nut. The gap between center slide and back plate is to be roughly about 0.1mm.

## **ADJUST THE PUNCH RAM (IW-50A Only)**

The alignment of the punch ram is guided by a "guide pad" inside the ram holder. When the ram is loose and starts to swivel or when the ram is misaligned (not square with the die base), the punch ram should be adjusted.

To adjust the punch ram, follow these steps:

- 1) Take off the warning plate in front of the punch ram.
- 2) Take out the two screws found underneath the warning plate and then the adjusting screws will be exposed.
- 3) Adjust the adjusting screws to press the guide pad uniformly on the ram. Do not over adjust the guide pad.
- 4) Check the adjustment by moving the ram up and down with non-round (oblong or square) punches and dies. The ram should be moving smoothly and without any swivel gaps.
- 5) Screw back the two outside screws to prevent loosening
- 6) Put back the warning plate.

## PUNCHING STATION

### Standard Equipment

The machine is equipped with one set of Ø20mm round punch and die. Many other punching tools of different sizes are also available upon request. In addition, a large 2-piece support table with gauges is installed as standard equipment.

**IMPORTANT:** The punch stripper must be closed properly during operation. On some models with an interlock limit switch inside the stripper back cover, the punching station is **IMMOBILIZED** if the stripper is open.

### Alignment of Punch and Die

The punch and the die may have previously been centered. However, you should check the tools regularly for proper alignment. To center the die, follow these steps:

- 1) Insert Punch into Retaining Nut, then tighten the nut onto the Retaining Thread.
- 2) Insert the Die into the Holder and secure the set screw.
- 3) Loosen all of the die holder fixing bolts
- 4) Lower the punch gradually (by using the JOG mode).

**WARNING: Be very careful that the punch does not hit the die which can break the punch and create a hazard.**

- 5) After the punch is inside the die, turn power off and isolate the machine.
- 6) Adjust the position of the Die Holder until the Clearance around the punch and die is even all the way around.
- 7) Tighten the die holder bolts to fix the die position.
- 8) Adjust the limit switches to change the stroke length if necessary.

When setting up square or oblong punches and dies, be sure to properly locate the key on top of the punch in the keyway of the punch retaining thread. Check carefully the alignment (both position and direction) of the die with the punch. Incorrect set up will damage the punch and die, and may cause danger.

**IMPORTANT:** Be sure to check the alignment of the punch and die whenever tools are changed.

### Punch and Die Clearance

Punch size is the same as the desired hole size. Die size is bigger by the

clearance. The clearance depends on the thickness of the material. The clearance is usually about 10% of the material thickness. Please also refer to the following chart for recommend clearance.

Material Thickness	mm	up to 4	4 - 9	9 - 14	14 - 20
Die Clearance	mm	0.2	0.7	1.2	1.7

### **Adjusting Stripper**

- The distance between the stripper and the material should be adjusted to about 2~3mm. Adjust the stripper height each time when changing to material of different thickness.
- Adjust the stripper height by turning the large knurled screws at both sides of the stripper.
- If the stripper tend to fall down at the right side, tighten the spring at the left side of stripper.
- Make sure the stripper is at even height for left and right sides. The stripper should be adjusted so that the work-piece contact the stripper evenly when the punch retracts out of the material. Unbalanced stripping may break the punch and cause hazard.
- If the material cannot have adequate contact with the stripper when stripping, such as asymmetrical material, material too small, or punched hole too close to the edge of material, do not proceed with the punching operation.

The stripper has exchangeable plates with various opening sizes to match the size of the hole. Select the plate with the smallest suitable opening. Keeping the opening close to the size of punch will greatly reduce deformation, especially on thinner materials.

### Actual Punching Force

The actual force required in a punching operation is calculated by the circumference of the hole multiplied by the thickness of material multiplied by tensile strength of material.

$$\text{Max. Capacity} = \text{circumference} \times \text{thickness} \times \text{tensile strength}$$

The capacity chart is based on material with 45 kg/mm<sup>2</sup> tensile. Do not attempt a punching operation that requires force over the maximum capacity of the machine.

### Precaution

- 1) Always use die with the proper clearance.
- 2) Always check the alignment after each tool change.
- 3) To prevent overloading and breakage of the punch, do not punch material which is thicker than the hole diameter,
- 4) Do not punch partial holes. Punching incomplete holes will cause the punch and die to bend and break.
- 5) Applying some lubricant oil on the punch will prolong the life of the punch and reduce the stripping load.
- 6) Regrinding of punching tools is not recommended.

### Punch and Die Lubricant

SHELL	-	GARIA 927
B. P.	-	SERVORA 68
CASTROL	-	ILOBROACH 219
DUCKHAMS	-	ADFORNOL EP7
JOSEPH BATSON	-	LB 733

## Punch Operation

### Punching on Flat Plates:

- 1) Make sure the notcher safety cover and punching stripper are closed.  
Turn the Punch/Shear/Notch switch to PUNCH.
- 2) Check again that the stripper, punch/die alignment is properly adjusted, and the height of the stripper is adjusted to about only 2 to 3mm above the work material.
- 3) Set the gauging stoppers to the desired position.
- 4) Position the plate on the working table against the stoppers.
- 5) Press the foot switch to the DOWN position to execute the punch.
- 6) Release the foot switch for the punch to retract. During stripping, the material can be lifted up against the stripper and then dropped off when the punch retracts out of the hole. **Be very careful with fingers as the material movement has potential of hazard.**

### Punching on Angles:

- 1) Make sure the notcher safety cover and punching stripper are closed.  
Turn the Punch/Shear/Notch switch to PUNCH.
- 2) Check again that the stripper, punch/die alignment is properly adjusted, and the height of the stripper is adjusted to about only 2 to 3mm above the work material.
- 3) Remove the front piece of the 2-piece table.
- 4) Set the gauging stoppers to the desired position.
- 5) Position the angle against the die holder with one flange facing downward. **Do not position the angle with one flange facing upward.** See figure.
- 6) Press the foot switch to the DOWN position to execute the punch.
- 7) Release the foot switch for the punch to retract. During stripping, the material can be lifted up against the stripper and then drop off when the punch retracts out of the hole. **Be very careful with fingers as the material movement has potential of hazard.**

### Punching on Channels:

- 1) Make sure the notcher safety cover and punching stripper are closed.  
Turn the Punch/Shear/Notch switch to PUNCH.

- 2) If punching the channel web, use the single-hole die holder with the table removed. If punching the channel flange, use the optional overhang two-hole die holder with the lower support portion and the front piece of the 2-piece table removed. Special goose-neck die holder is also available for punching both channel web and channel flange. See figure.
- 3) Check again that the stripper, punch/die alignment is properly adjusted, and the height of the stripper is adjusted to about only 2 to 3mm above the work material.
- 4) If punching channel web, position the channel with both flanges facing downward. If punching channel flange, position the channel with the flange being punched on top. See figure.
- 5) Press the foot switch to the DOWN position to execute the punch.
- 6) Release the foot switch for the punch to retract. During stripping, the material can be lifted up against the stripper and then drop off when the punch retracts out of the hole. **Be very careful with fingers as the material movement has potential of hazard.**

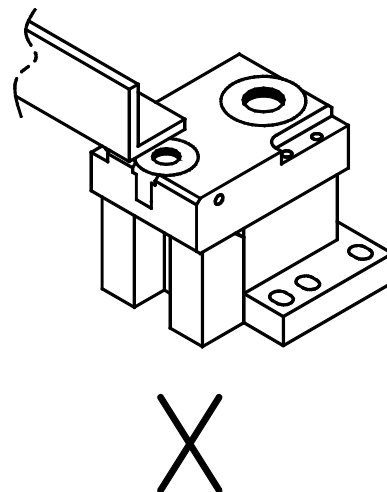
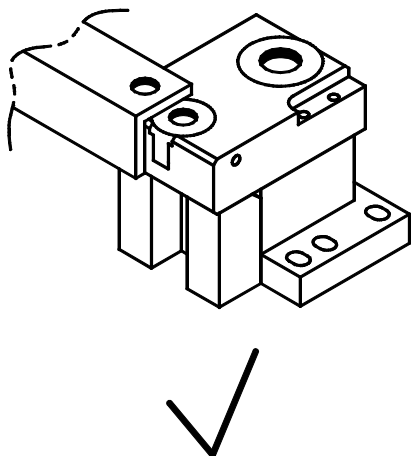

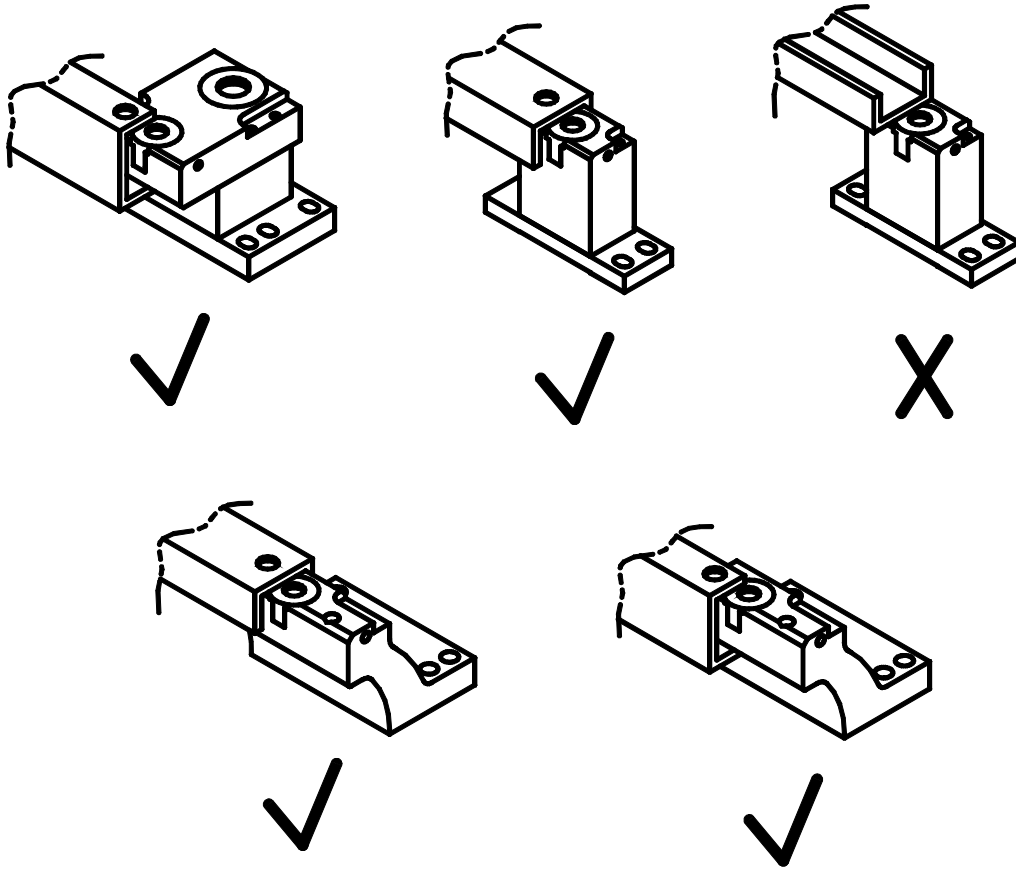

## Punching Station Assembly

Retaining Thread Support  
(IW-45M,IW-60H)

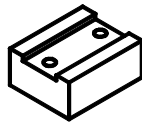

Punch Ram  
(IW-50A)



Punch Retaining Thread



Punch Retaining Nut

Round Punch



Oblong Punch



Punch Sleeve

## **FLAT BAR SHEAR STATION**

This station is equipped with a hold down suitable for shearing of various material thickness. The machine also comes with a feed table with guides for material support and positioning. Besides shearing flat bars, this station can also shear the flange of angles.

### **Blades**

**Upper Blade (Moving):** The moving shearing blade has a special curved cutting edge to minimize distortion on the shearing cuts. The moving blade can be turned to utilize both cutting edges.

**Lower Blade (Stationary):** The stationary blade can be turned for the use of all four cutting edges to provide a long blade life.

### **Cutting Clearance**

The width of the cutting clearance (the distance between the moving and stationary blades) had been pre-adjusted in the factory to be between 0.2 and 0.3mm. The cutting clearance depends on the thickness and tensile strength of the material. The thicker the material, the wider the cutting clearance should be. Improper cutting clearance can result in the deformation of the working piece. Too large of clearance when shearing thin material can cause the material to bend over instead of being sheared.

The cutting clearance can be adjusted by the fix bolts that "pull in" the stationary blade and the adjusting screws that "push out" the stationary blade. To adjust clearance, follow these steps:

- 1) In JOG mode, move down the top blade to the lower position so that the opening between blades are closed.
- 2) Turn power OFF and isolate the machine.
- 3) Remove the holddown and the feed table.
- 4) Loosen the large fixing bolts that holds the lower blade.
- 5) Loosen the locking nuts on the adjust screws.
- 6) Adjust the clearance by turning the adjusting screws which push the lower blade towards the upper blade.
- 7) Check clearance using a feeler gauge. **It is very important to make sure that the cutting clearance is uniform for the entire blade.**
- 8) Tighten the locking nut of the adjust screws to prevent loosening.
- 9) Tighten the fixing bolts to fix the position of lower blade.
- 10) Reinstall the table and holddown.

11) Check clearance again to ensure even clearance.

### Precaution

- 1) **Do not shear any piece too small to be secured in position by the holddown. Doing so can seriously damage the machine beyond repair. See Figure.**
- 2) Always feed cutting material from front. NEVER insert material from back.
- 3) Keep the cutting edges sharp. Check the sheared material to see whether the cutting clearance is properly set and that the condition of the blades are O.K.
- 4) Clean the scraps and waste materials regularly and keep the work area clean.

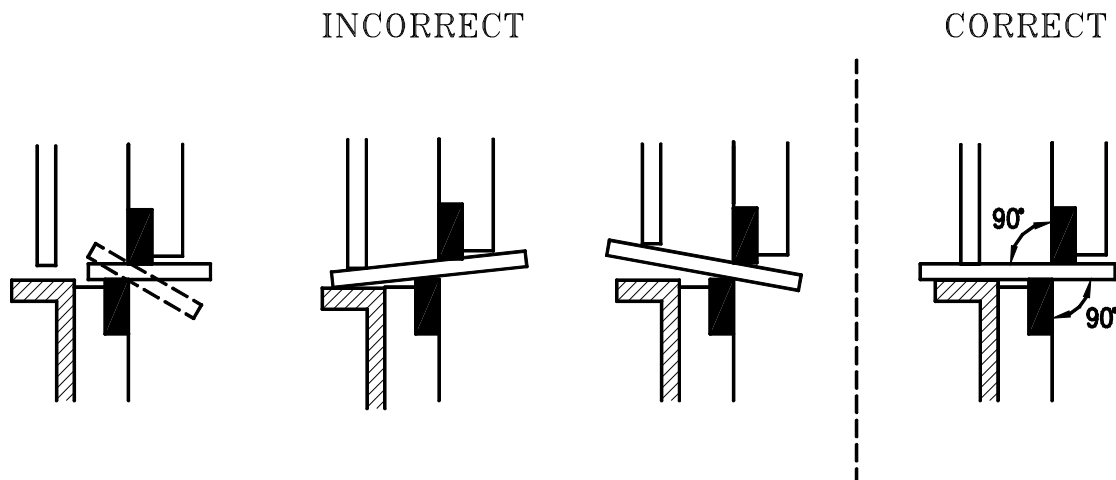

### **Flat bar Shear Operation**

- 1) Make sure the notcher safety cover and punching stripper are closed. Turn the Punch/Shear/Notch switch to SHEAR.
- 2) Push the material under the hold-down to the desired length. Use the backgauge for getting the precise length.
- 3) Make sure that the material is properly positioned on the table and under the hold-down. Incorrect positioning can damage the blades and/or the machine.
- 4) Use the guide stoppers on the table to position and stabilize the material.
- 5) Lower the hold-down to firmly press the material.
- 6) Tighten the two hand knob nuts to fix the hold-down in position.
- 7) Press the foot switch to execute the shear and release foot switch for the slide to move back up. Alternatively the electric backgauge can be used. See section on Electric Backgauge for details.

### **Angle Flange Shear Operation**

The vertical slot on the hold-down allows the shearing of angle flanges at various degrees. To operate:

- 1) Make sure the notcher safety cover and punching stripper are closed. Turn the Punch/Shear/Notch switch to SHEAR.
- 2) Push the material into the vertical slot on the hold-down until the vertical flange touches the upper blade.
- 3) Align the material to the desired shearing degree using the marks on the feeding table, then use the movable guide to stabilize the material.
- 4) Lower the hold-down to firmly press the material.
- 5) Tighten the two hand knob nuts to fix the hold-down in position.
- 6) Press the foot switch to execute the shear and release foot switch for the slide to move back up. Electric backgauge should not be used in this operation.

## **ANGLE SHEAR STATION**

This working station can do 90-degree shear on Angles as well as 45-degree internal miter shear. On IW-60H, external miter shear is also possible. Feed the material through the central slot on the hold-down for 90-degree shear. On IW-45M and IW-50A, feed the material through the slots on the top and side of the hold-down for different directions of 45-degree internal shear. On IW-60H, feed the material through the two slots on the hold-down for internal and external 45-degree shear.

At 45-degree miter shear, the blades cut both flanges of the angle. So when matching two angles to make a turning joint, the gap between the vertical flanges is at minimum.

### **Blades**

**Stationary Blades:** The two stationary blades each has 4 cutting edges. Turn the blades to use the other cutting edges.

**Moving Blade:** The moving blade also has 4 cutting edges. Turn the blade diagonally to use the other cutting edges. To avoid the blade making a mark on the material, the tip of moving blade can be grounded to match the inside radius of the angle steel.

**NOTE:** On the IW-60H, there are total of 4 blades for this station, one large, one small moving blade, and one large, one small stationary blade.

Keep the blades clean. Remove all small slugs and other waste material. Do not allow mill scale to build up in the blade area.

### **Cutting Clearance**

The clearance between the moving blade and the stationary blades were pre-adjusted to be between 0.2mm and 0.3mm. The cutting clearance can be adjusted by the fix bolts that "pull in" the stationary blades and the adjusting screws that "push out" the stationary blades. To adjust the clearance, follow the following steps:

- 1) In JOG mode, move down the moving blades to lower position so that the opening between the blades are closed.
- 2) Turn power OFF and isolate the machine.



## **SUNRISE Fluid Power Inc.**

No. 7, Road 12, Industrial Zone, Taichung City 407, Taiwan

Tel: 886-4-2359-1190

sales@sunriseiw.com.tw

Fax: 886-4-2359-3409

www.sunriseiw.com

---

- 3) Remove the hold-down.
- 4) Loosen the large blade fixing bolts.
- 5) Loosen the locking nuts on the adjust screws.
- 6) Adjust the clearance by turning the adjusting screws which push the stationary blade towards the moving blade
- 7) Check clearance using a feeler gauge. **It is very important to make sure the cutting clearance is uniform for the entire blades.**
- 8) Tighten the locking nut of the adjust screws to prevent loosening.
- 9) Tighten the fixing bolts.
- 10) Check clearance again to ensure even clearance.
- 11) Reinstall the hold-down.

### **90 Degree Shear Operation**

- 1) Make sure the notcher safety cover and punching stripper are closed. Turn the Punch/Shear/Notch switch to SHEAR.
- 2) Push the angle through the slot on the holddown to desired length. Use the backgauge for getting the precise length.
- 3) Adjust the screw on the hold-down so that the tip of the screw lies at the root of the angle. The hold-down screw should be tightened so that the working piece does not move upwards while being cut.
- 4) Press the foot switch to execute the shear and release foot switch for the slide to move back up. Alternatively the electric backgauge can be used. See section on Electric Backgauge for details.



**45 Degree Internal Miter Shear Operation (on IW-45M and IW-50A)**

- 1) Make sure the notcher safety cover and punching stripper are closed. Turn the Punch/Shear/Notch switch to SHEAR.
- 2) Insert the Angle through the guide slot on the side of the hold down to shear the flanges of angle at 45 degree.
- 3) Insert the another piece of Angle through the guide slot on the top of the hold down to shear the flanges of angle at 45 degree of opposite direction.
- 4) Match the two angles to get an 90 degree turning joint.

Note: The electric backgauge should not be used for this operation.

**45 Degree Internal/External Miter Shear Operation (on IW-60H only)**

- 1) Make sure the notcher safety cover and punching stripper are closed. Turn the Punch/Shear/Notch switch to SHEAR.
- 2) Insert the Angle through the guide slot on the side of the hold down to shear the flanges of angle at 45 degree. The feeding material and the cut-off material will be one each of internal and external miter shear.
- 3) Insert another piece of Angle through the other guide slot on side of the hold down to shear the flanges of angle at 45 degree of opposite direction. The feeding material and the cut-off material will be one each of internal and external miter shear, opposite in direction from the previous shear.
- 4) Match two angles to get an 90 degree turning joint.

Note: The electric backgauge should not be used for this operation.

IW-45M

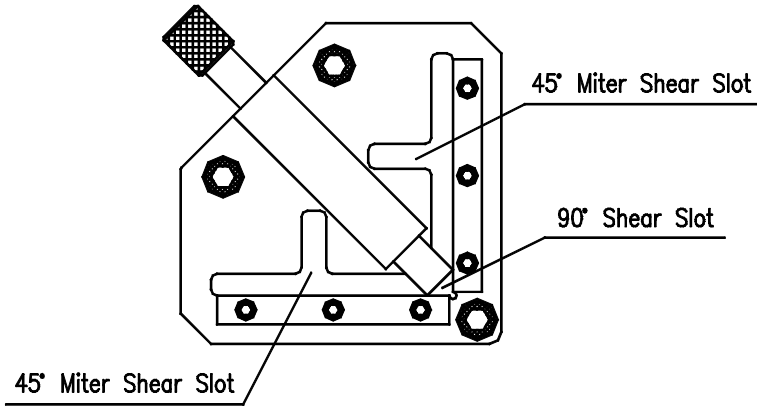

IW-50A

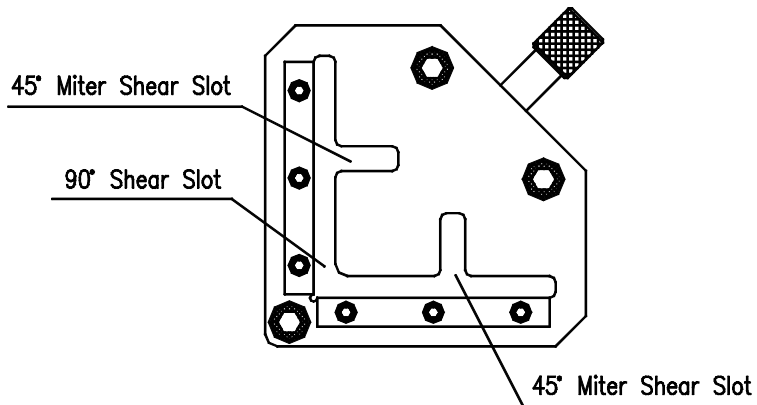

IW-60H

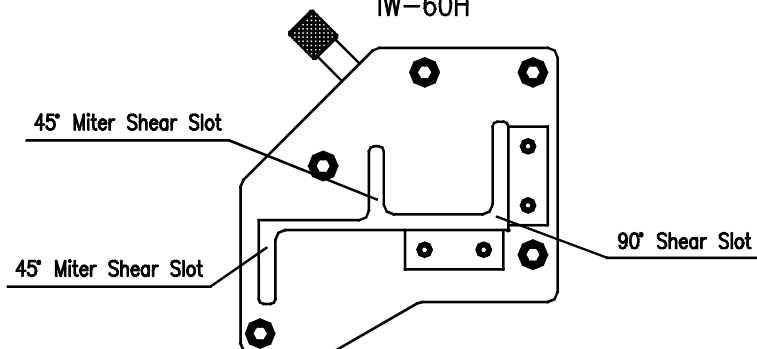

## **SQUARE/ROUND BAR SHEAR STATION**

This station is equipped with a hold down suitable for shearing various sizes of square and round bars. As optional tooling, this station can also shear various type of channels or section bars by changing the moving and stationary blades and hold-downs.

### **Cutting Clearance**

Adjustment of the clearance of the bar shear station is by the adjust screws that push-in the stationary blade against the moving blade. To adjust clearance, follow these steps:

- 1) Turn power OFF and isolate the machine.
- 2) Remove the holddown.
- 3) Loosen the locking nuts.
- 4) Tighten the pushing screws. Then loosen each screw *slightly* to leave about 0.1mm~0.2mm space for blade clearance. Lock in position by tighten the locking nuts.
- 5) Reinstall the holddown.

### **Precaution**

- 1) **Do not shear any piece too small to be secured in position by the holddown.**
- 2) Always feed cutting material from front. NEVER insert material from back.
- 3) Clean the scraps and waste materials regularly and keep the work area clean.

### **Bar Shear Operation**

- 1) Make sure the notcher cover and punching stripper are closed.
- 2) On IW-45M and IW-50A, turn Punch/Shear/Notch switch to SHEAR to use this station.  
On IW-60H, turn Punch/Shear/Notch switch to PUNCH to use this station.
- 3) Push the bar through the slot on the holddown to desired length. Use of the backgauge for precise length.
- 4) Adjust the holddown so that the bar is perpendicular to the blades.
- 5) Tighten the two hand knob nuts to fix the position of holddown.
- 6) Press the foot switch to execute the shear and release foot switch for the slide to move back up. Alternatively the electric backgauge can be used. See section on Electric Backgauge for details.



**SUNRISE Fluid Power Inc.**

No. 7, Road 12, Industrial Zone, Taichung City 407, Taiwan

Tel: 886-4-2359-1190

sales@sunriseiw.com.tw

Fax: 886-4-2359-3409

www.sunriseiw.com

---

Note: On IW-45M the holddown for this station is the same as the holddown for the flat shear station.

## **NOTCHING STATION (On IW-50A and IW-60H)**

The rectangular notcher is very useful to notch the edges and corners of flat plates, as well as to notch the flanges of Angles. The triangular Vee-notcher is also available as an optional tooling.

On IW-45M, the notcher is optional tooling to be installed at the punching station.

### **Blades**

The three lower blades each has four cutting edges. Turn the blades to use the other cutting edges. The top blade cannot be turned. We do not suggest grinding of these blades.

### **Bolster Adjustment**

The notch bolster can be adjusted for alignment of the lower blades with the upper blade. To adjust, follow these steps:

- 1) Make sure the punching stripper is closed. Select NOTCH mode on the Punch/Shear/Notch switch and JOG mode on the Normal/Jog switch.
- 2) Lower the working slide until the upper blade inserts into the lower blades by about 3 to 5 mm below the top surface of the lower blades.
- 3) Turn power OFF and isolate the machine.
- 4) Loosen the bolster fixing bolts.
- 5) Loosen the nut on the side adjust screws.
- 6) Loosen the nut for the back hold-back bolt.
- 7) Adjust the bolster position by turning the side adjust screws and the back hold-back bolt.
- 8) Check the cutting clearances on all three cutting faces with a feeler gauge.  
**It is very important to make sure the cutting clearance is uniform for the entire blades at all 3 cutting faces.**
- 9) Tighten the nuts for the side adjust screws and the back hold-back bolt to lock the screw/bolt in position.
- 10) Tighten the bolster fix bolts to fix the position of the bolster.
- 11) Check clearance again to ensure even clearance.

### **WARNING on notching safety cover:**

The nature of the notch station requires opening the notcher safety cover

during notching operation for processing different shape and sizes of materials. This creates a potential risk to the operator. The notcher safety cover is interlocked by a key at the SHEAR/NOTCH selection switch. **The key is intended for properly trained and authorized operators only.** Misusage of the key may increase the risk of injury at the Notching station. When using the notching station, open the notcher safety cover only as much as the job required. If notching flat plate, do not open the cover all the way up. **NEVER LEAVE THE KEY ON THE MACHINE.**

**Notcher safety cover must be closed when not using the notching station.** During notching operation, **always make sure that no fingers and other body parts are near the blade cutting edges.** Use the gauging stoppers on the notcher table to position the material. **Do not notch material that operator cannot hold firmly during notching.** Operator is warned by a flashing warning light when safety cover is opened. Exercise caution and be alert to potential risks.

### Notching Operation

- 1) Make sure the punching stripper is closed. Turn the Punch/Shear/Notch switch to NOTCH. The stroke movement of the slide is shorter in Notch mode for better safety.
- 2) Open the safety cover.
- 3) Position the plate or angle on the support table. Use the gauging stoppers on the support table for more accurate and safer operation.
- 4) Adjust the screws on the two strippers to just 1~2mm above the material.
- 5) Press the foot switch to execute the notch and release foot switch for the slide to move back up. During stripping, the material can be lifted up against the stripper and then drop off when the top blade retracts out of the material. **Be very careful with fingers as the material movement has potential of hazard.**
- 6) **Close the safety cover after each operation. Do not leave the cover open.**

## MAINTENANCE

### 1. **Before operating the machine:**

Routinely check the electrical power cable and the foot switch cable for any loosening or damage.

Inspect all the blades, punch, die, and safety guards to ensure they are in good condition.

Clean all slugs, cut off pieces, and other waste material from each work stations and around the machine.

### 2. **Filter and Oil Change:**

Take off and clean the suction filter inside the oil tank every time when changing oil. The first oil change should be performed after approximately 600 operating hours. Further oil change is needed for every 1200 operating hours. A drain outlet is located at the base of the oil tank.

Screw back the cleaned suction filter after the draining the oil. If the suction filter is damaged or clogged, replace the suction filter. Do not mix different brands of oil.

Hydraulic Fluid (or equivalent)

Mobil	DTE 46
Esso	Nuto H46
Shell	Tellus 46 or Hydraulic oil 46
B.P.	Energol HLP 46
Castrol	Hyspin AWS 46 6018

### 3. **Lubrication**

Lubricate the machine with recommended grease every 8 working hours.

Use the grease gun provided to supply grease to all lubrication points which are located on both sides of the machine. (See section on Lubrication)

**4. Oil level:**

Make sure the hydraulic oil level is in the range indicated on the oil level gauge. It is better to keep the oil level close to the high mark indicated on the gauge.

Model	Capacity (liter)	Oil Required (liter)
IW-45M	65	47
IW-50A	86	66
IW-60H	96	73

**5. Oil temperature:**

The oil temperature should be under 50 degrees Celsius. If the upper/lower limit switches are not set correctly for unloading of the pump, the oil temperature can raise quickly. Adjust the limit switches so the pump will be in the unloading condition.

**6. Hydraulic pressure:**

The working pressure of the hydraulic system is pre-set in the factory. The pressure should ONLY be adjusted by the service engineer. There is a pressure gauge to indicate the working pressure of the machine. The pressure gauge should be locked and be used only during service/maintenance work.

Model	IW-45M	IW-50A	IW-60H
<b>Max Pressure</b>	210 Kg/cm <sup>2</sup>	240 Kg/cm <sup>2</sup>	250 Kg/cm <sup>2</sup>

**AIRBORNE NOISE**

The continuous airborne noise level of the machine under normal condition is approximately 75 dB ± 5 dB.

## **TROUBLE SHOOTING**

<b>Problem</b>	<b>Probable cause</b>	<b>Solution</b>
Motor cannot start	1. No power.	Check the power source.
	2. Isolator switch not turn on.	Turn the switch to ON position.
	3. Emergency buttons not released.	Release both emergency buttons by turning knob to the right.
	4. Motor broken.	Replace motor.
	5. Motor power cable not connected properly.	Check the cable connection and reconnect cable. Change cable if worn out.
	6. Motor circuit breaker jumped to OFF.	Reset the breaker to ON position.
	7. Fuse broken.	Check and replace fuse.
	8. Magnetic switch broken or burn out.	Replace switch
	9. Transformer broken.	Replace transformer
Motor is on, but machine won't move	1. Motor turning in wrong direction.	Turn machine off. Change any two of the three power source wire. Re-check motor direction.
	2. Not enough hydraulic oil.	Check oil level and add oil if necessary.
	3. Solenoid valve stuck.	Clean or replace valve.
	4. Solenoid valve coil burn out.	Replace solenoid valve.
	5. Foot pedal not sending signal.	Check pedal and replace switch if necessary.
	6. Relay stuck or burn out.	Replace relay



**SUNRISE Fluid Power Inc.**

No. 7, Road 12, Industrial Zone, Taichung City 407, Taiwan

Tel: 886-4-2359-1190

sales@sunriseiw.com.tw

Fax: 886-4-2359-3409

www.sunriseiw.com

<b>Problem</b>	<b>Probable cause</b>	<b>Solution</b>
(cont.)	7. Interlocked safety covers not closed.	Close covers/stripper.
	8. Limit switch not set at correct position.	Adjust the limit switch for proper stroke travel setting.
Machine moves, but cannot reach capacity	1. Relieve valve not set correctly	Check hydraulic pressure and adjust relieve valve (tighten to increase pressure)
	2. Relieve valve broken.	Replace relieve valve.
	3. Pump broken.	Replace pump.
	4. Cylinder internal leak.	Contact dealer for service.
	5. Pilot check valve not set correctly.	Adjust the correct pressure setting of the valve.
Excess hydraulic noise	1. Motor turning wrong direction.	Turn machine off. Change any two of the three power source wire. Re-check motor direction.
	2. Pump worn out.	Replace pump.
	3. Filter is dirty.	Replace filter element.
	4. Not enough oil.	Check oil level and add oil if necessary.

# Hydraulic Circuit

## IW-45M-50A,60H

(with low pressure JOG)

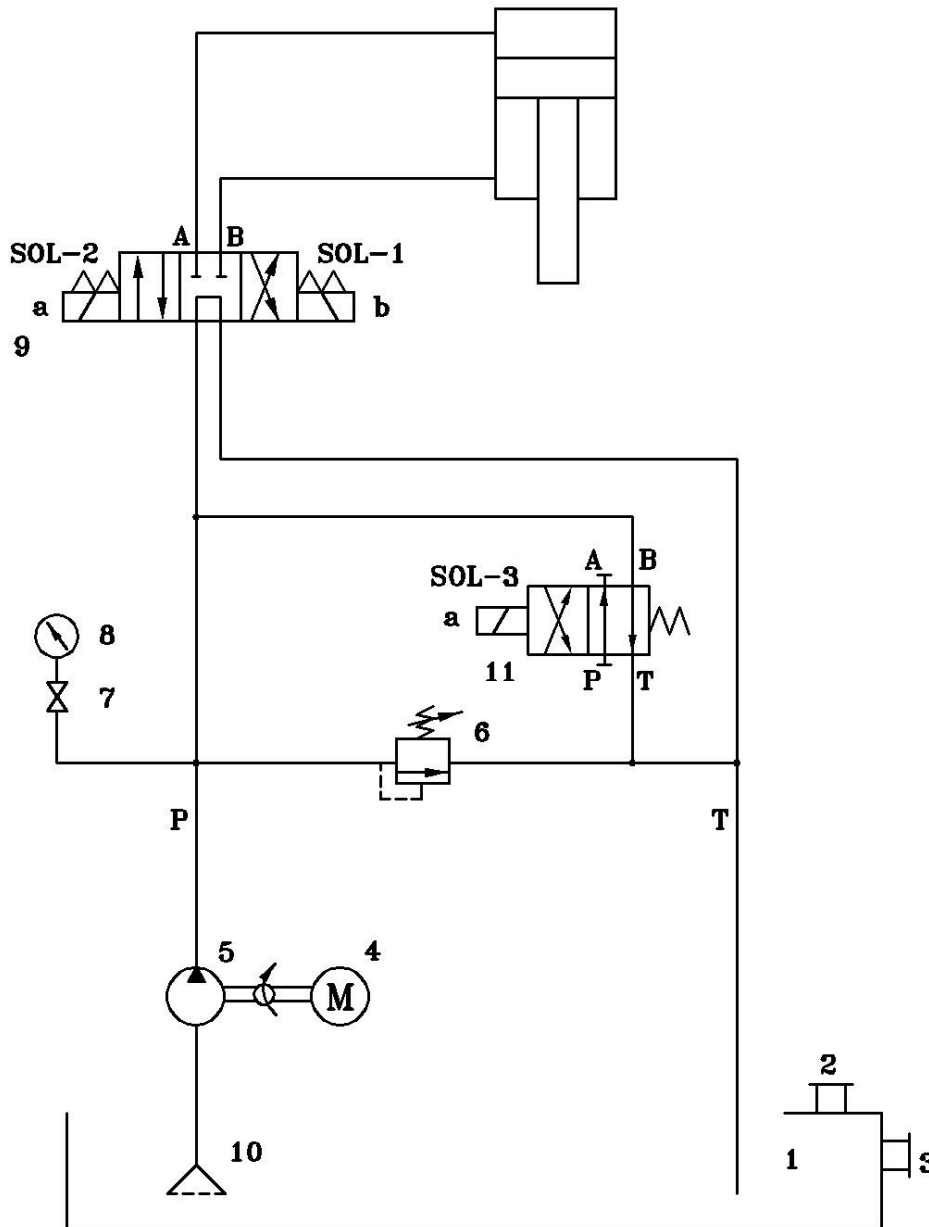

1703202.DWG 12/2012

## Hydraulic Circuit Parts



**SUNRISE Fluid Power Inc.**

No. 7, Road 12, Industrial Zone, Taichung City 407, Taiwan

Tel: 886-4-2359-1190

sales@sunriseiw.com.tw

Fax: 886-4-2359-3409

www.sunriseiw.com

**IW-45M, IW-50A, IW-60H**

(with low pressure JOG)

No.	Description	Qty	Specification / Part No.
1	Tank	1	IW-45M: 211702940 (JOG) IW-50A: 211802920 (JOG) IW-60H: 211902920 (JOG)
2	Breather & Filter	1	53702HY08A
3	Oil Level Gauge	1	53701LG4
4	Motor	1	IW-45M: 5 HP IW-50A: 5 HP IW-60H: 7.5 HP
5	Pump	1	IW-45M: 53201GHP2AS20E IW-50A: 53201ALP2AS16 IW-60H: 53201GHP2AS22
6	Relief Valve	1	53656RPECFAN
7	Gauge Cock	1	53652ST02L
8	Pressure Gauge	1	53621CBLM63350
9	Solenoid Valve	1	53651DFA02005
10	Suction Oil Filter	1	IW-45M: 53301MF086 IW-50A: 53301MF086 IW-60H: 53301MF106
11	Solenoid Valve	1	53651DFA02001

**Electrical Circuit (CE)**  
*1W-45M model with JOG*

- SB1: EMERGENCY STOP
- SB2: PUMP OFF
- SB3: PUMP ON
- FS: FOOT SWITCH
- QF: MOTOR CIRCUIT BREAKER
- SA1: PUNCH/SHEAR
- SA2: NORMAL/JOG
- SO1: RAM UP STOP
- SO2: RAM DOWN STOP
- SO3: PUNCH SAFETY INTERLOCK

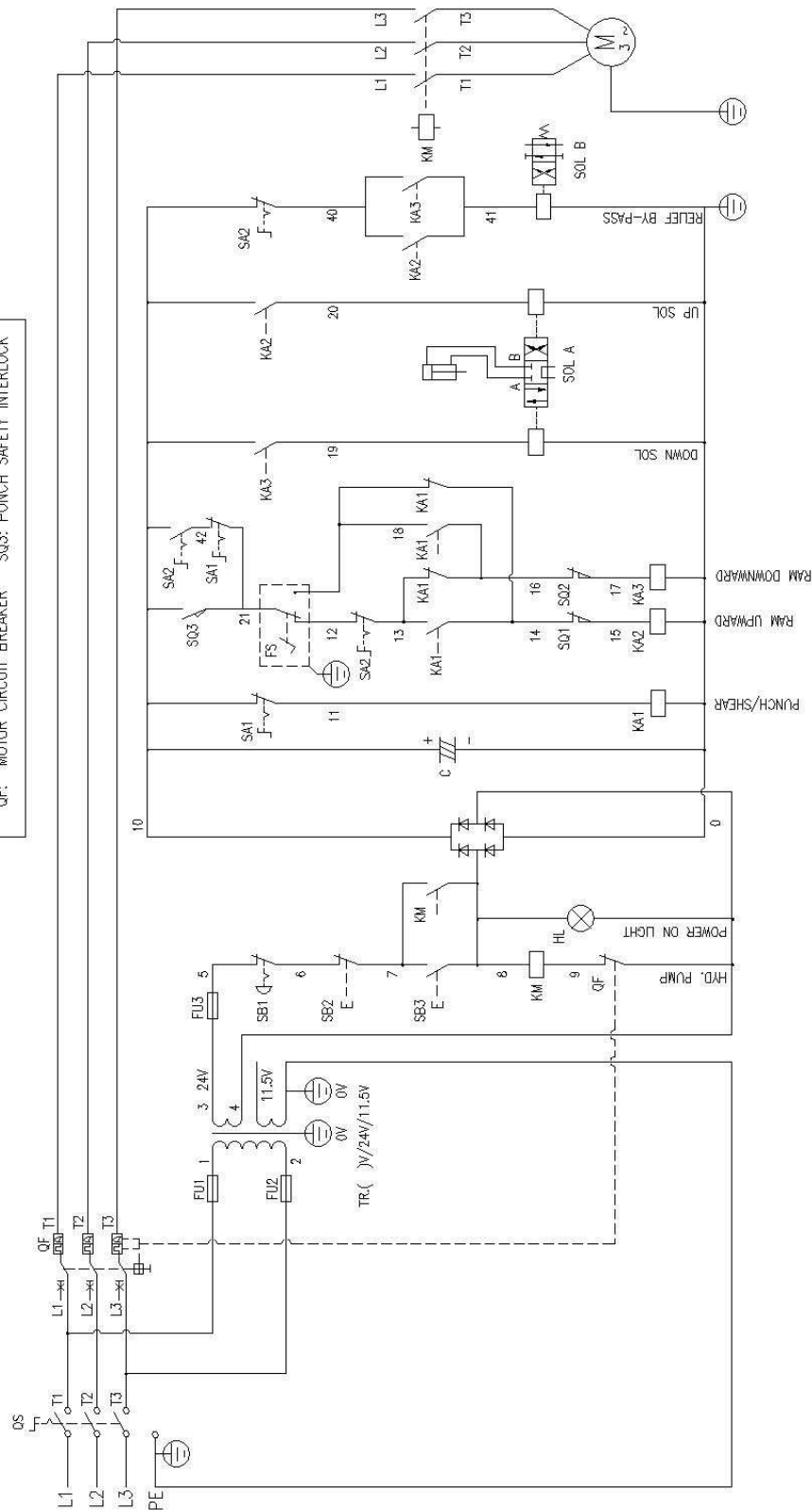

L1	L2	L3	PE	21	12	18	5	6	14	15	16	17	10	21	19	20	41	0	0	0
POWER SOURCE			FS	SA1	SA2	SO1	SO2	SO3	SOL											

SB2: PUMP OFF (1B)  
 SB3: PUMP ON (1A)  
 SA1: PUNCH/SHEAR (2B)  
 SA2: NORMAL/JOG (1A / 2B)

1704202E 12/2012

## Electrical Parts

### IW-45M (CE)

(with low pressure JOG)

Code	Description	Quantity	Function
QF	Motor Circuit Breaker	1	Motor Protection
FU1,FU2,FU3	Fuse	3	Control Circuit Protection
QS	Isolator Switch	1	Circuit Interrupter
SB1	Push-Lock Push Bottom	1	Emergency Stop
SB2	Flush Push Bottom (Red)	1	Pump Off
SB3	Flush Push Bottom (Green)	1	Pump On
SA1	Selector Switch	1	Punch / Shear Switch
SA2	Selector Switch	1	Normal / Jog Key Switch
FS	Foot Switch	1	Foot Switch Control
KA1	Relay	1	Punch / Shear
KA2	Relay	1	Ram Upward
KA3	Relay	1	Ram Downward
SQ1	Limit Switch	1	Ram Up Limit Switch
SQ2	Limit Switch	1	Ram Down Limit Switch
SQ3	Limit Switch	1	Punch Safety Interlock
SOL A	Solenoid Valves	1	
SOL B	Solenoid Valves	1	
KM	Magnetic Switch (Contactors)	1	
	Bridge Rectifiers	1	
Tr	Transformer	1	

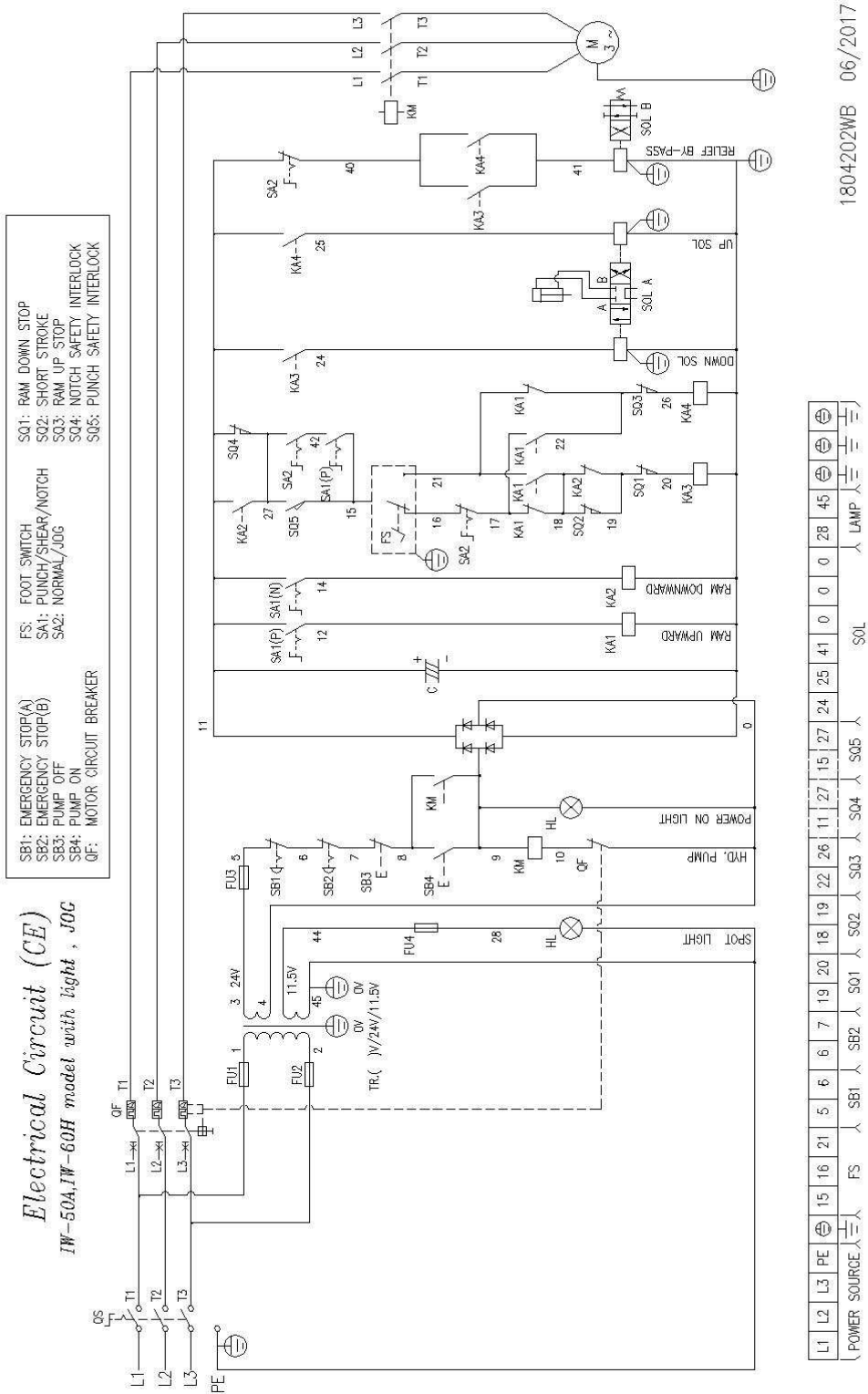

SB3: PUMP OFF (1B)  
 SB4: PUMP ON (1A)  
 SA1: PUNCH/SHEAR/NOTCH (3A) (P-2A N-1A)  
 SA2: NORMAL/JOG (1A / 2B)

## Electrical Parts IW -50A, IW-60H (CE)

(with low pressure JOG, working light)

Code	Description	Quantity	Function
QF	Motor Circuit Breaker	1	Motor Protection
FU1,FU2,FU3	Fuse	3	Control Circuit Protection
FU4	Fuse	1	Spot Light Protection
QS	Isolator Switch	1	Circuit Interrupter
SB1,SB2	Push-Lock Push Bottom	2	Emergency Stop
SB3	Flush Push Bottom (Red)	1	Pump Off
SB4	Flush Push Bottom (Green)	1	Pump On
SA1	Selector Switch	1	Punch/Shear/Notch Switch
SA2	Selector Switch	1	Normal/Jog Key Switch
FS	Foot Switch	1	Foot Switch Control
KA1	Relay	1	Punch/Shear Stroke
KA2	Relay	1	Notch Stroke
KA3	Relay	1	Ram Downward
KA4	Relay	1	Ram Upward
SQ1	Limit Switch	1	Ram Down Limit Switch
SQ2	Limit Switch	1	Short (Notch) Stroke Limit Switch
SQ3	Limit Switch	1	Ram Up Limit Switch
SQ4	Limit Switch	1	Notch Safety Interlock
SQ5	Limit Switch	1	Punch Safety Interlock
SOL A	Solenoid Valve	1	
SOL B	Solenoid Valve	1	
KM	Magnetic Switch	1	
	Bridge Rectifiers	1	
Tr	Transformer	1	

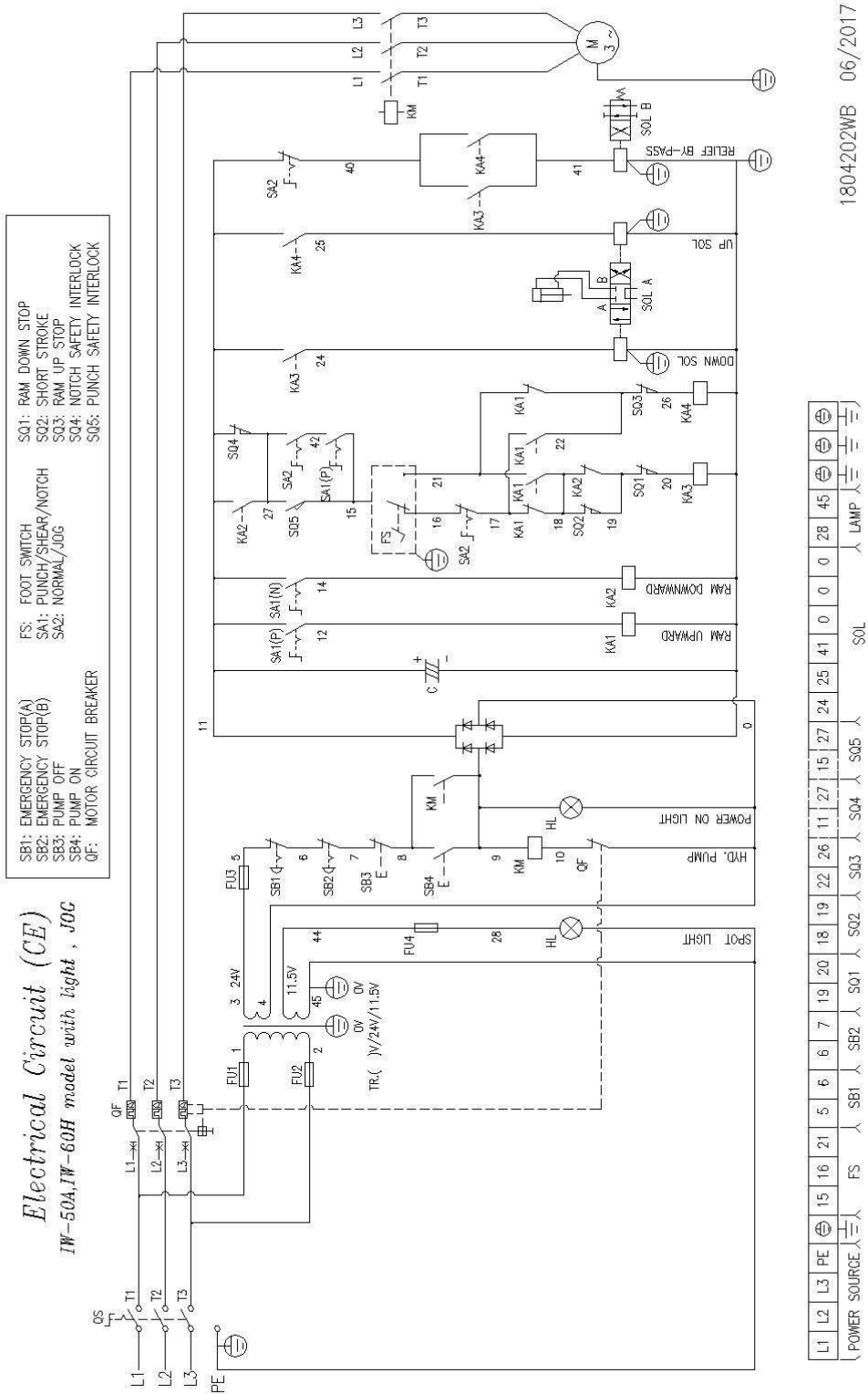

## Electrical Parts IW-50A, IW-60H (CE)

(with low pressure JOG, Electric backgauge, working light)

Code	Description	Quantity	Function
QF	Motor Circuit Breaker	1	Motor Protection
FU1,FU2,FU3	Fuse	3	Control Circuit Protection
FU4	Fuse	1	Spot Light Protection
QS	Isolator Switch	1	Circuit Interrupter
SB1,SB2	Push-Lock Push Bottom	2	Emergency Stop
SB3	Flush Push Bottom (Red)	1	Pump Off
SB4	Flush Push Bottom (Green)	1	Pump On
SA1	Selector Switch	1	Punch/Shear/Notch Switch
SA2	Selector Switch	1	Normal/Jog Key Switch
SA3	Selector Switch	1	Auto/Manual Switch
FS	Foot Switch	1	Foot Switch Control
KA1	Relay	1	Punch/Shear Stroke
KA2	Relay	1	Notch Stroke
KA3	Relay	1	Ram Downward
KA4	Relay	1	Ram Upward
KA5, KA6	Relay	2	Backgauge Sensor Control
SQ1	Limit Switch	1	Ram Down Limit Switch
SQ2	Limit Switch	1	Short (Notch) Stroke Limit Switch
SQ3	Limit Switch	1	Ram Up Limit Switch
SQ4	Limit Switch	1	Notch Safety Interlock
SQ5	Limit Switch	1	Punch Safety Interlock
TIMER	Timer for Electric Backgauge	1	Sensor Timer
SENSOR	Sensor	1	Backgauge Sensor
SOL A	Solenoid Valve	1	
SOL B	Solenoid Valve	1	
KM	Magnetic Switch	1	
	Bridge Rectifiers	1	
Tr	Transformer	1	