

IW-60S/SD

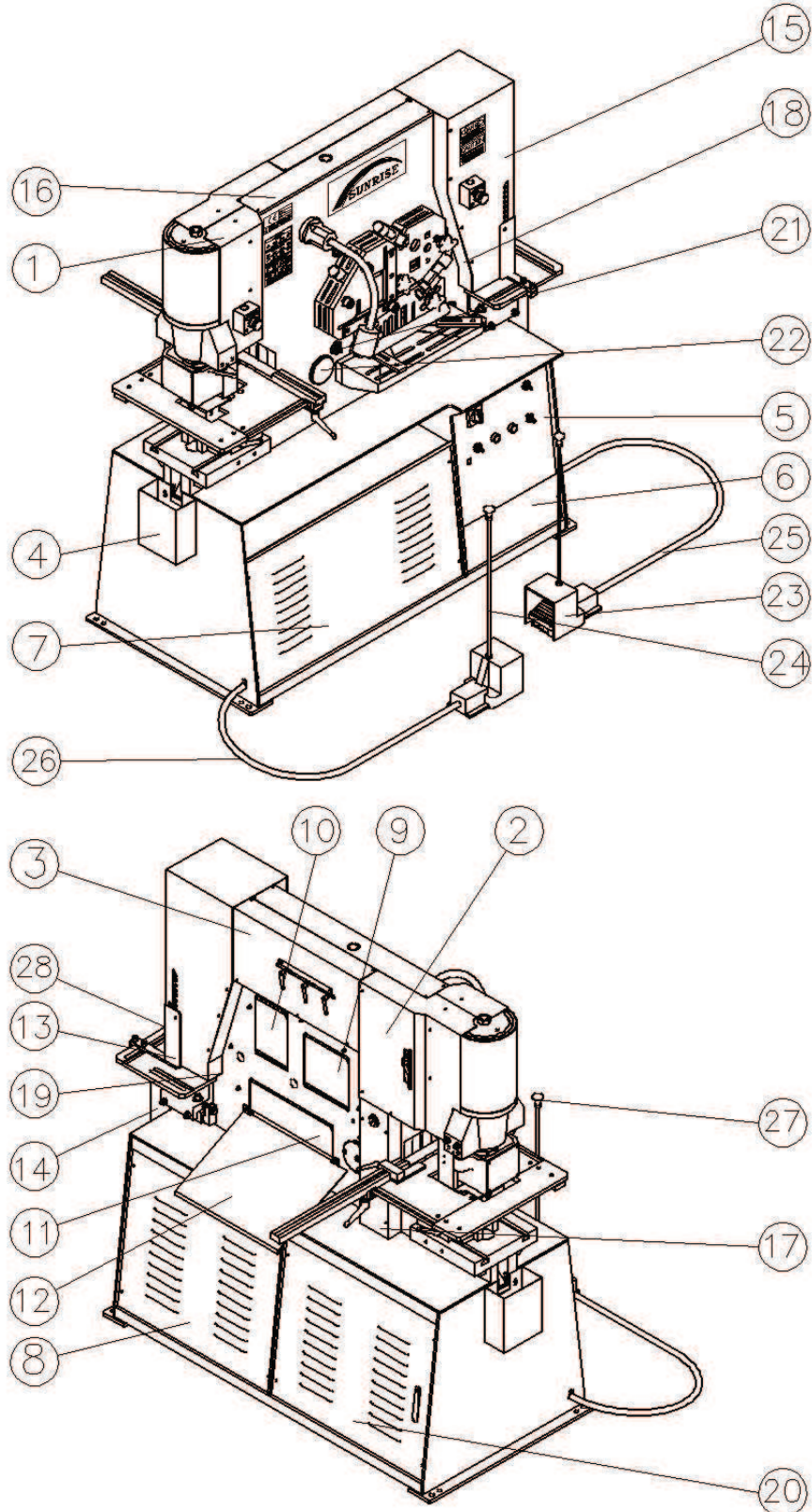



SUNRISE Fluid Power Inc.

No. 7, Road 12, Industrial Zone, Taichung City 407, Taiwan

Tel: 886-4-2359-1190

Fax: 886-4-2359-3409

sales@sunriseiw.com.tw

www.sunriseiw.com.tw

Sunrise Ironworker Parts List

Model: IW-60S /SD

Part: Cover Plates

Date: 02/2012

Item	Part Number	Description	產品名稱	Q'ty	Memo
1	213002006D	Punching Cylinder Cover A	沖孔油壓缸護蓋 A	1	
2	60S: 213002034A 60SD: 213102009A	Punching Cylinder Cover B	沖孔油壓缸護蓋 B	1	
3	60S: 213002008F 60SD: 213102006C	Shearing Limit Switch Cover	剪切限動調整護蓋	1	
4	211302021A	Scrap Box For Punching	沖孔鐵屑盒	1	
5	213002902A	213002022E 213002023A 211302025C 52414APL93902	Electrical Box	1	
6	213202022C	Front Base Cover	電氣箱底座護蓋	1	
7	60S: 213002001 60SD: 213102001	Front Base Cover	底座前蓋	1	
8	60S: 213002002 60SD: 213102002	Rear Base Cover A	底座後蓋 A	1	
9	213002014	Safety Guard for Angle Shear	剪角鐵護板	1	
10	213002015	Safety Guard for Bar Shear	剪圓方護板	1	
11	213002016	Safety Guard for Flat Shear	剪平板護板	1	
12	213002019A	Flat Bar Shear Back Plate	滑料片	1	
13	213002036C	Safety Guard For Notching	剪角安全護板	1	
14	211302022	Scrap Box For Notching	剪角鐵屑盒	1	
15	213002035C	Notching Cylinder Cover	剪角油壓缸護蓋	1	
16	60S: 213002005C 60SD: 213102004B	Top Cover	上護蓋	1	
17	213002031	Hose Cover	配管套蓋(電動定位尺)	1	
18	213002009A	Notching Side Cover A (Front)	護蓋固定板 A (前)	1	
19	213002010A	Notching Side Cover B (Rear)	護蓋固定板 B (後)	1	
20	60S: 213002003 60SD: 213102003	Rear Base Cover B	底座後蓋 B	1	
21	213010005 211310008B	Adjust Pushing Screw Adjust Pushing Nut	壓塊固定螺絲 壓塊固定螺帽	4	
22	213010001B	Main Pivot Pin	支持點心軸	1	
23	52413YC135D	Foot Switch YC-135D(CE)	腳踏開關	2	
24	213210008	Foot Switch Handle	腳踏開關提桿	2	
25	60S: 56320G0061300A 60SD: 56320G0061400A	Foot Switch Cable 3/8"X1300mm Foot Switch Cable 3/8"X1400mm	電線保護管 1300mm 電線保護管 1400mm	1	
26	56320G0061300A	Foot Switch Cable 3/8"X1300mm	電線保護管 1300mm	1	
27	56314118036M10	Waist Shaped Knobs 1180-36-M10	凹槽式旋鈕	2	
28	213002037	Notching Clear Cover	剪角壓克力護板	1	

Punching Station Assembly for Double Cylinder Models

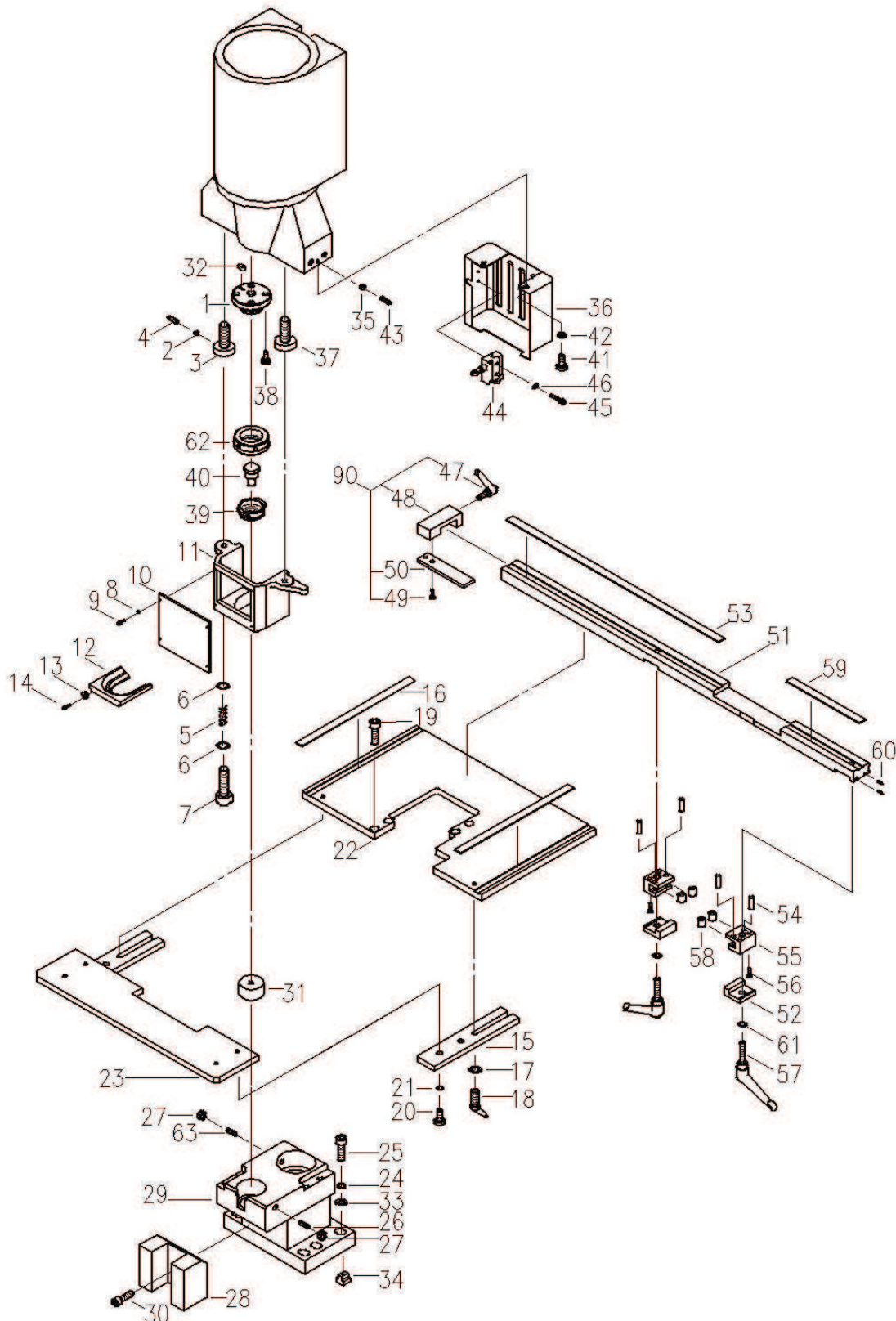



SUNRISE Fluid Power Inc.

No. 7, Road 12, Industrial Zone, Taichung City 407, Taiwan

Tel: 886-4-2359-1190

Fax: 886-4-2359-3409

sales@sunriseiw.com.tw

www.sunriseiw.com.tw

Sunrise Ironworker Parts List

Model: IW-60S/SD, 80S/SD

Part: Punching Station

Date: 02/2012

Item	Part Number	Description	產品名稱	Q'ty	Memo
1	42RTBQA	Retaining Thread	螺紋塊	1	
2	211305090	212211009	Copper Piece	銅墊	1
3		211305005B	Stripper Adj. Screw (2)	剝料器調整螺桿(二)	1
4		56301C0006010	Set Screw M6X10	止付內六角螺栓	1
5		211305006	Stripper Spring	沖孔剝料器彈簧	1
6		56303D00012024045	Flat Washer M12	平墊圈	2
7		56301A0012090	Hex Bolt M12X90	六角承窩頭螺栓	1
8		42STBD	56303A00005	Spring Washer M5	彈簧墊圈
9	56301A0005012		Hex Bolt M5X12	六角承窩頭螺栓	4
10	42STBC002		Stripper Clear Cover	剝料器安全護板	1
11	42STBC006A		Stripper	沖孔剝料器	1
12	42STBC003A-20 42STBC003A-42 42STBC003A-52		Stripper Exchangeable Plate	剝料器底板	1
13	42STBC004		Washer	墊片	2
14	56301I0005008		Cap Screw M5X8	半圓內六孔	2
15	212205005C		Table Connecting Plate	工作板組合塊	2
16	S: 213005006A SD: 213105002A	Punching Table Ruler 306mm Punching Table Ruler 506mm	沖孔工作板Y軸標尺	2	
17	56303B11012025	Flat Washer M10	平墊圈	2	
18	56315404192M1032	Clamp Handle M10X32	萬向把手	2	
19	S: 213005110 SD: 213105110	56301A0010020	Hex Bolt M10X20	六角承窩頭螺栓	4
20		56301A0010030	Hex Bolt M10X30	六角承窩頭螺栓	4
21		56303A00010	Spring Washer M10	彈簧墊圈	4
22		S: 213005001C SD: 213105001D	Punching Table A (Main)	沖孔工作板(A)	1
23		213005002	Punching Table B (Front)	沖孔工作板(B)	1
24		56303A00016	Spring Washer M16	彈簧墊圈	6
25	56301A0016060	Hex Bolt M16X60	六角承窩頭螺栓	6	
26	56301C7010060	Set Screw M10X60	止付內六角螺栓	1	
27	56302B0110	Nut M10	螺帽	2	
28	43B3DMC	43B1D005A	Die Holder Support	下模座支持塊	1
29		43B3DM900D	Overhang Die Holder (Ø45/Ø80)	雙孔沖孔座	1
30		56301A0012020	Hex Bolt M12X20	六角承窩頭螺栓	1



SUNRISE Fluid Power Inc.

No. 7, Road 12, Industrial Zone, Taichung City 407, Taiwan

Tel: 886-4-2359-1190

Fax: 886-4-2359-3409

sales@sunriseiw.com.tw

www.sunriseiw.com.tw

Model: IW-60S/SD, 80S/SD

Part: Punching Station

Date: 02/2012

Item	Part Number	Description	產品名稱	Q'ty	Memo	
31	41RD1	Die	圓孔下模	1		
32	56305D00606018	Locating Key	雙頭圓鍵	1		
33	56303D00016032045	Flat Washer M16	平墊圈	6		
34	211305011	T-Shaped Nut M16	T形螺帽	6		
35	213205010	Copper Piece	銅墊	2		
36	213202034	Stripper Rear Guard	剝料器護板	1		
37	211305004B	Stripper Adj. Screw (1)	剝料器調整螺桿(一)	1		
38	56301A0012025	Hex Bolt M12X25	六角承窩頭螺栓	4		
39	42RSBQ30A 42RSBQM40B 42RSBQM50B	Quick Change Sleeve	快拆上模套環	1		
40	41RP1	Punch	圓孔上模	1		
41	56301A0006010	Hex Bolt M6X10	六角承窩頭螺栓	2		
42	56303A00006	Spring Washer M6	彈簧墊圈	2		
43	56301C0010020	Set Screw M10X20	止付內六角螺栓	2		
44	52411AZ7312	Limit Switch	微動開關	1		
45	56301A0004025	Hex Bolt M4X25	六角承窩頭螺栓	2		
46	56303B10005010	Flat Washer M4	平墊圈	2		
47	213005141	56315404163M1020	Clamp Handle M10X20	萬向把手	1	
48		213205004	Stopper Piece	X軸定位板	1	
49		56301F0006016	Sunk Head Hex Bolt M6X16	皿頭六角承窩螺栓	2	
50		212205007S1	Stopper Piece	沖孔定位塊	1	
51		213205018B	Punching Stopper Guide	Y軸定位板	1	
52		213205020	Stopper Guide Base	定位板固定滑塊	2	
53		213005015	Punching Stopper Guide Ruler 602.5mm	Y軸定位尺標尺(左)	1	
54		56306R0080030	Pin Ø8X30	直銷 Ø8X30	4	
55		213205019	Stopper Y-axis Guide	Y軸定位滑座	2	
56		56301A4006030	Hex Bolt M6X30	六角承窩頭螺栓	4	
57		56315404192M1050	Clamp Handle M10X50	萬向把手	2	
58		56309DTA815	Needle Bearing TA815	滾針軸承 TA815	4	
59		213005014	Punching Stopper Guide Ruler 207.5mm	Y軸定位尺標尺(右)	1	
60		56301C0005008	Set Screw M5X8	止付內六角螺栓	2	
61		56303B11012025	Flat Washer M10	平墊圈	2	

Angle and Bar Shear Station for Double Cylinder Models

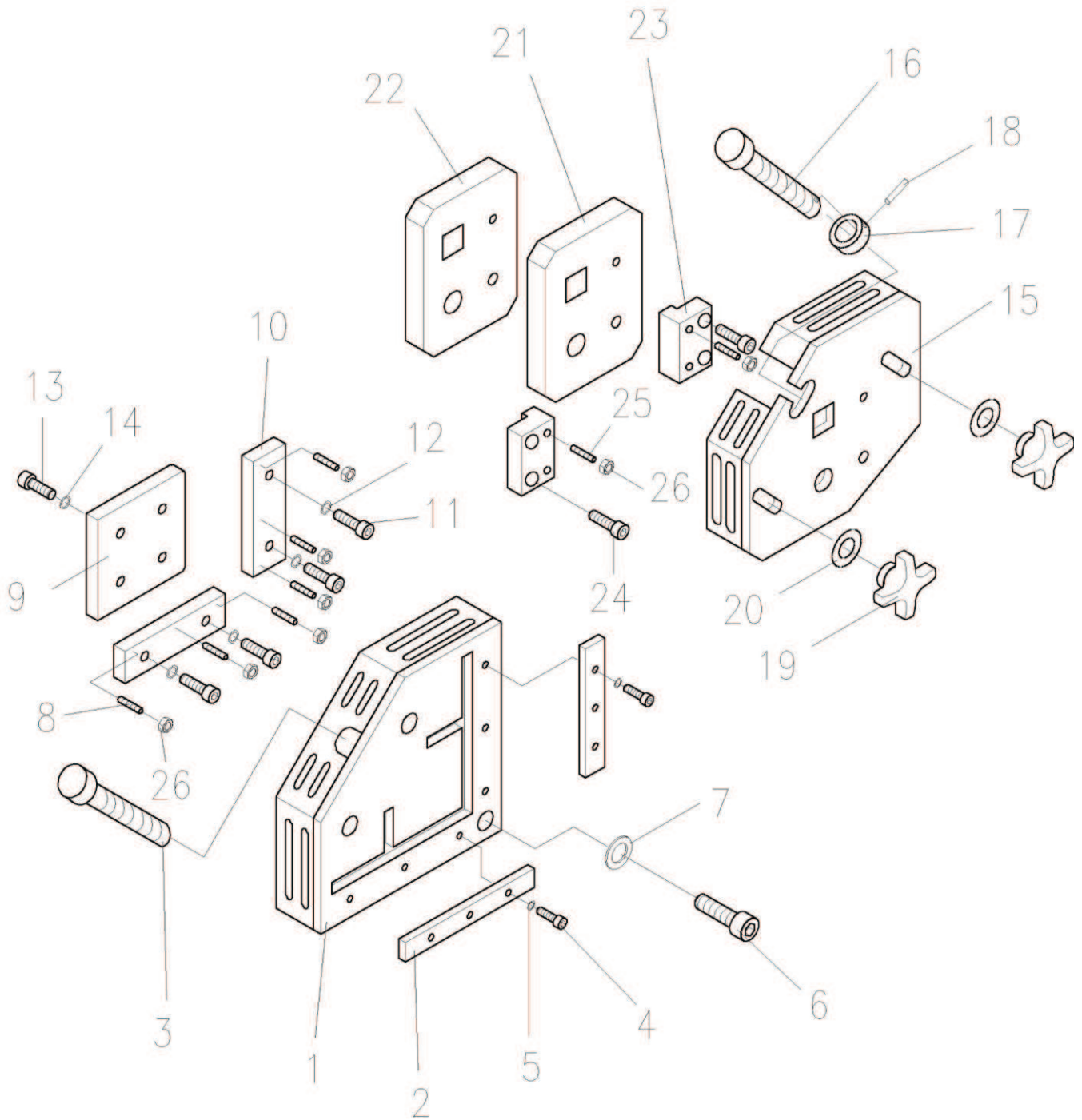

PART3007A.dwg 02/2020



SUNRISE Fluid Power Inc.

No. 7, Road 12, Industrial Zone, Taichung City 407, Taiwan

Tel: 886-4-2359-1190

Fax: 886-4-2359-3409

sales@sunriseiw.com.tw

www.sunriseiw.com.tw

Sunrise Ironworker Parts List

Model: IW-60S/SD

Part: Angle and Bar Shear Station

Date: 02/2012

Item	Part Number		Description	產品名稱	Q'ty	Memo
1	213007900C	213007001E	Angle Shear Holddown	角鐵剪切座	1	
		213007004				
		213002017D				
		213002018D				
2	211307005A		Angle Holddown Adjusting Plate	L型鐵座調整塊	2	
3	211310009		Angle Holddown Screw	L型鐵座調整螺桿	1	
4	56301A0010025		Hex Bolt M10X25	六角承窩頭螺栓	6	
5	56303A00010		Spring Washer M10	彈簧墊圈	6	
6	56301A0020030		Hex Bolt M20X30	六角承窩頭螺栓	3	
7	56303B00020037040		Flat Washer M20	平墊圈	3	
8	56301C8010030		Set Screw M10X30	止付內六角螺栓	6	
9	213007003C		Angle Shear Moving Blade	角鐵剪切刀具(活動)	1	
10	213007002B		Angle Shear Stationary blade	角鐵剪切刀具(固定)	2	
11	56301A0014040		Hex Bolt M14X40	六角承窩頭螺栓	4	
12	56303A00014		Spring Washer M14	彈簧墊圈	4	
13	56301A0014050		Hex Bolt M14X50	六角承窩頭螺栓	3	
14	56303A00014		Spring Washer M14	彈簧墊圈	3	
15	213009900	213009003	Rd/Sq Shear Holddown	圓方壓板	1	
		213002012				
		213002013A				
16	213210900	213210009	Shear Holddown Screw	平板,圓方壓塊移動螺桿	1	
17		211310011	Holddown Screw End Piece	調整螺桿拉塊	1	
18		56306S0060030	Spring Pin Ø6X30	彈簧銷	1	
19	56314DIN633576		Fix Nut for Holddown	十字旋鈕(不銹鋼)	2	
20	56303D00016040070		Flat Washer M16	平墊圈	2	
21	213009001		Rd/Sq Shear Stationary Blade	圓方刀具(固定)	1	
22	213009002		Rd/Sq Shear Moving Blade	圓方刀具(活動)	1	
23	211309004		Rd/Sq Shear Blade Fix Plate	圓方刀具固定塊	2	
24	56301A0012020		Hex Bolt M12X20	六角承窩頭螺栓	4	
25	56301C8010040		Set Screw M10X40	止付內六角螺栓	4	
26	56302B0110		Nut M10	螺帽	10	

Flat Shear Station for IW-60H & IW-S/SD

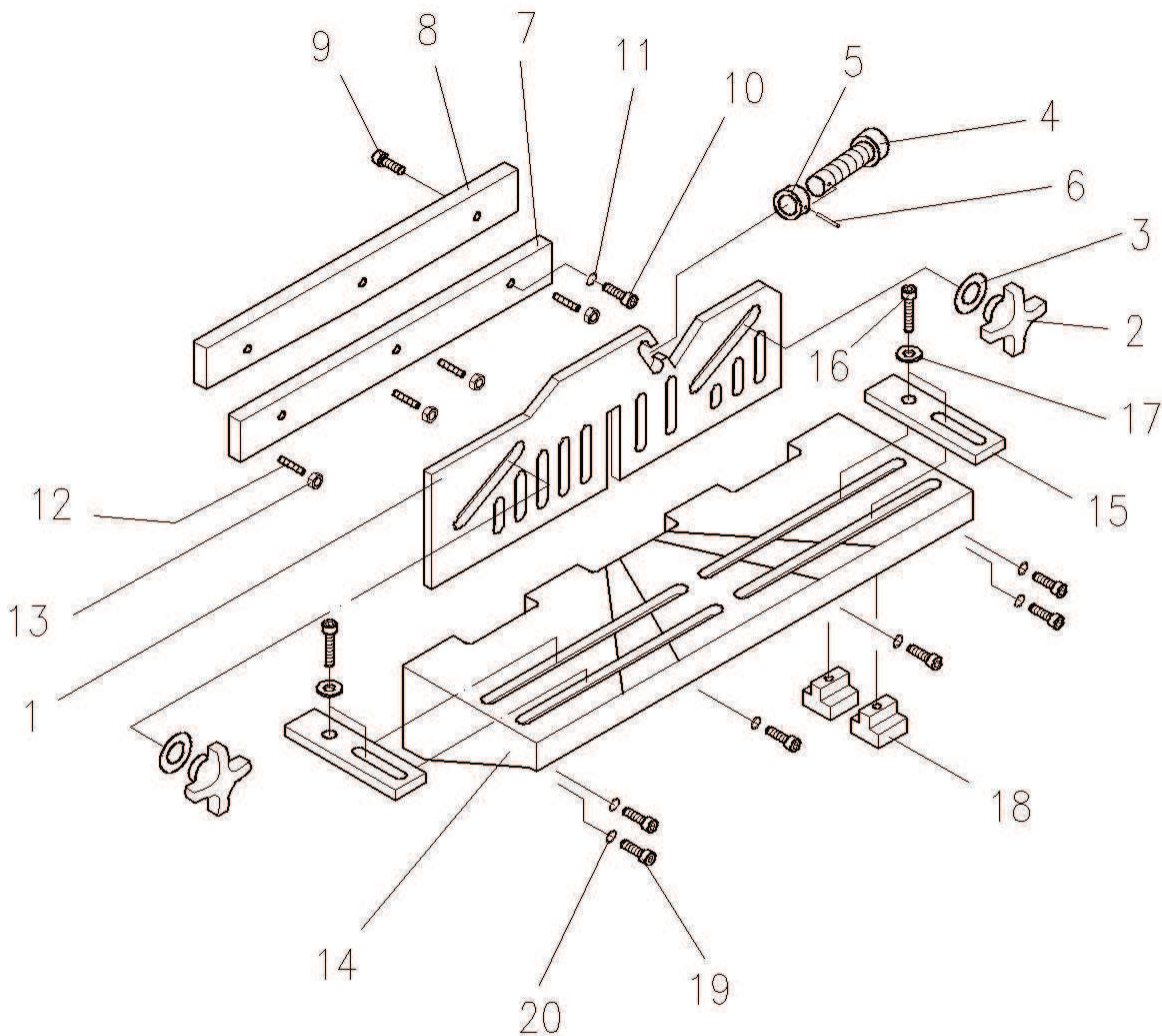

PART3008A.dwg 04/2010

Notching Station Assembly for Double Cylinder Models

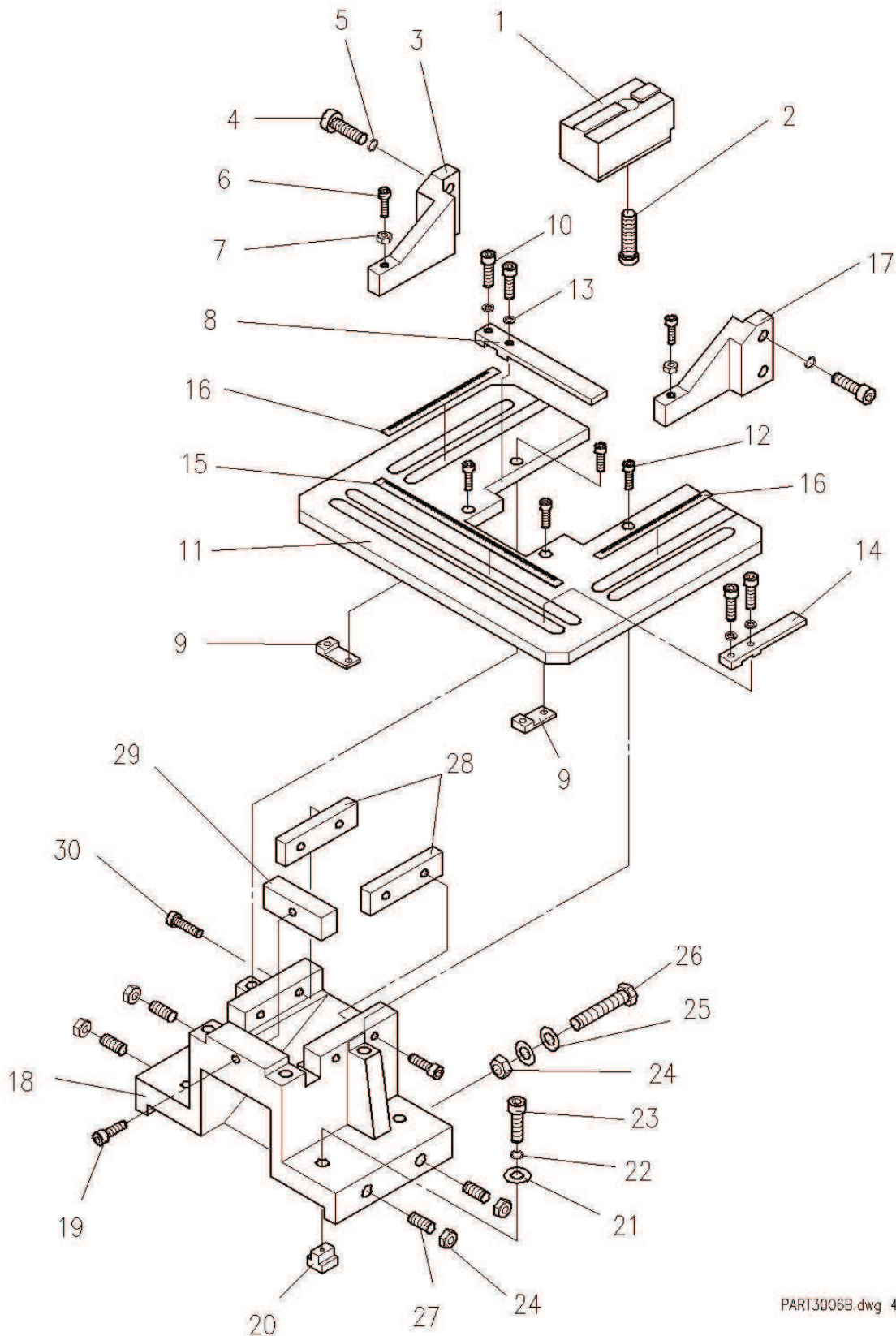



SUNRISE Fluid Power Inc.

No. 7, Road 12, Industrial Zone, Taichung City 407, Taiwan

Tel: 886-4-2359-1190

Fax: 886-4-2359-3409

sales@sunriseiw.com.tw

www.sunriseiw.com.tw

Sunrise Ironworker Parts List

Model: IW-60S/SD,80S/SD

Part: Notching Station

Date: 02/2012

Item	Part Number	Description	產品名稱	Q'ty	Memo
1	213206001A	Notcher Top Blade	方形剪角上刀	1	
2	56301A0018050	Hex Bolt M18X50	六角承窩頭螺栓	1	
3	211306004A	Notching Stripper (left)	剪角剝料器(左)	1	
4	56301A0012035	Hex Bolt M12X35	六角承窩頭螺栓	4	
5	56303A00012	Spring Washer M12	彈簧墊圈	4	
6	56301A0008050	Hex Bolt M8X50	六角承窩頭螺栓	2	
7	56302B0108	Nut M8	六角螺帽	2	
8	213206100	213206003A	Stopper Plate (long)	工作板定位塊	1
9		211605009A	Clamping Plate	定位板固定滑塊	2
10		56301A0010040	Hex Bolt M10X40	六角承窩頭螺栓	4
11		213206002B	Notching Table	剪角工作板	1
12		56301A0008016	Hex Bolt M8X16	六角承窩頭螺栓	4
13		56303A00010	Spring Washer M10	彈簧墊圈	4
14		211606004B	Stopper Plate (Short)	工作板定位塊	1
15		213206005B	Notching Table Ruler	剪角X軸標尺	1
16		213206006A	Notching Stopper Guide Ruler	剪角Y軸標尺	2
17	211306005A	Notching Stripper (right)	剪角剝料器(右)	1	
18	211306008D	Notching Bolster	剪角下模座	1	
19	56301A0010035	Hex Bolt M10X35	六角承窩頭螺栓	1	
20	211305012	T-Shaped Nut M12	T形螺帽	4	
21	56303D00012024045	Flat Washer M12	平墊圈	4	
22	56303A00012	Spring Washer M12	彈簧墊圈	4	
23	56301A0012050	Hex Bolt M12X50	六角承窩頭螺栓	4	
24	56302B0112	Nut M12	六角螺帽	6	
25	56303D00012024045	Flat Washer M12	平墊圈	4	
26	56301E0012060	Hex Bolt M12X60	外六角頭螺栓	2	
27	56301C8012035	Set Screw M12X35	止付內六角螺栓	4	
28	211306002F	Notcher Side Blade	方形剪角側刀	2	
29	211306003A	Notcher Front Blade	方形剪角前刀	1	
30	56301A0010020	Hex Bolt M10X20	六角承窩頭螺栓	4	

Stroke Adjustment for Double Cylinder Models

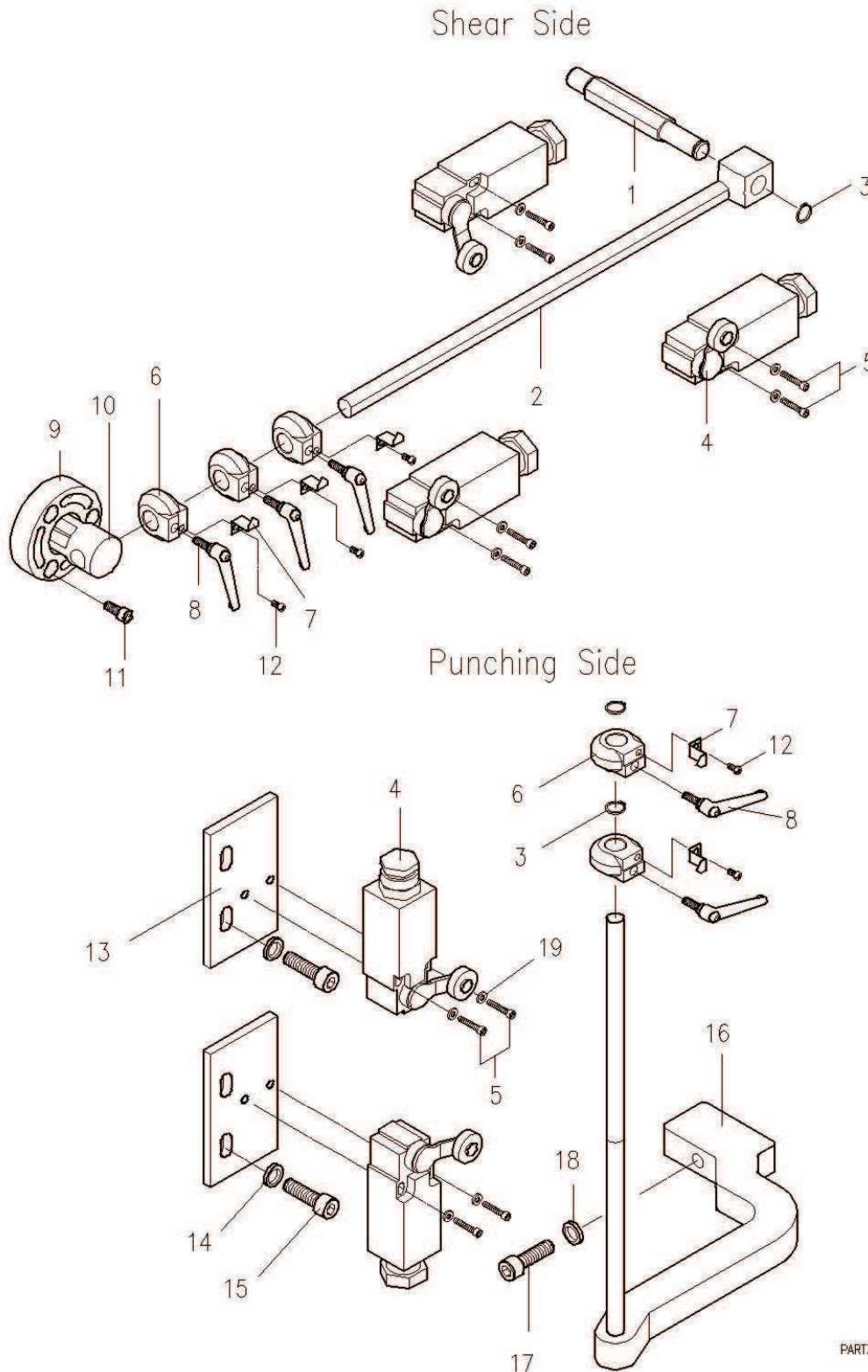

PART3004B.DWG 05/2010

